

Disassembly of Waste Electrical and Electronic Equipment (WEEE) Manual

EU Waste Electronic and Electrical Equipment Directive require producers to provide information of the different electronic and electrical materials and components found in their products at its end-of-life, and disassembly references to treatment and recycling facilities.

1. Product information
2. Materials and components list for selective treatment
3. Disassembly tools
4. Disassembly references

The following information is intended only for the use of recognized treatment and recycling facilities.

Section 1: Product information

Model name(s) — The product models are group together in series and are mechanically equivalent

Lexmark CS820 series –

CS820de, CS820dte, CS820dtfe, C6160, CS827de

Lexmark CX82x series –

CX820de, CX820dte, CX820dtfe, XC6152, XC6152de, CX827de, CX825de, CX825dte, CX825dtfe, XC8155, XC8155de

Lexmark CX860 series –

CX860de, CX860dte, CX860dtfe, XC8160, XC8160de

Section 2: Materials and components list for selective treatment

Table 2: Materials and components list for selective treatment

Description	Count	Notes
Polychlorinated biphenyls (PCB) containing capacitors	0	N/A
Mercury containing components, such as switches or backlighting lamps	0	N/A
Batteries	1	***** <u>Total Count = 1</u> ***** Lithium Manganese Oxide coin cell located on the Controller card
Printed circuit boards greater than 10 cm ²	multiple	***** <u>Minimum Count = 14</u> ***** For details, see Annex B ***** <u>Options:</u> 1 – 550 Sheet Tray 1 – Stapler *****
Toner cartridges, liquid and pasty, as well as colour toner	9	4 – Toner cartridge 4 – Imaging unit 1 – Waste toner bottle
Plastic component(s) that may contain BFR (brominated [§] flame retardants)	multiple	***** <u>Minimum Count = 36</u> ***** For details, See Annex A ***** <u>Options:</u> <u>+3</u> – for each 550 Paper handling *****
Note (§) - This product may contain plastic parts with brominated flame retardants. Recycler should treat these parts separately. See section 4.3 Disclaimer.		
Asbestos waste and components which contain asbestos	0	N/A
Cathode ray tubes	0	N/A
Chlorofluorocarbons (CFC), Hydrochlorofluorocarbons (HCFC) or Hydrofluorocarbons (HFC), Hydrocarbons (HC)	0	N/A
Gas discharge lamps	0	N/A
Liquid Crystal Display (LCD) greater than 100 cm ² and those back-lighted with Gas discharge lamps	1	1 (depending on which product model)
External electrical cables	1	Power cord located on the back lower left quadrant
Components containing refractory fibres	0	N/A
Components containing radioactive substances	0	N/A
Electrolyte capacitors containing substances of concern (capacitors with height > 25 mm, diameter > 25 mm or proportionately similar volume)	1	Capacitor located on Power Supply
Electrical and Electronic (EE) Customer Replaceable Paper handling devices	multiple	See Customer Replaceable Paper handling devices For details, See Annex C
Electrical and Electronic (EE) Customer Replaceable Internal/External Card options	multiple	See External Card options For details, See Annex D

Section 3: Common Tools for Disassembly

Table 3.1 - Disassembly tools

Item	Description
1	#2 Phillips screwdriver, magnetic
2	Wire cutter
3	E-clip puller or small flat-head screwdriver
4	Standard slotted head screwdriver





Section 4: Disassembly references

4.1 Removal procedure(s)

WEEE materials and components removal procedures are available upon request.

Please Contact: recycling@lexmark.com

4.2 Graphical illustration of material's and component's location

-  LCD > 100 cm²
-  PCBs > 10 cm²
-  Printer components containing Brominated flame retardants
-  Battery

Please note: Graphic illustrations contained in this document may differ slightly from actual components

4.3 Disclaimer

Statement on WEEE Bromine Levels

Manufacturer is compliant with the European Directive 2012/19/EU and European Commission's mandated technical specification CLC/TS 50625-3-1:2015 stating that plastic containing brominated flame retardants (BFR) must be removed from any separately collected WEEE (Article 8, Annex VII) if total bromine concentration in the fraction is known to be >2000 ppm, or expected to be >2000 ppm, or if it is not declared. Concentrations of bromine <2000 ppm are acceptable for reuse and do not require separation, so that the re-use and recycling of components or whole appliances is not hindered per Annex II, Section 3 of the WEEE Directive (2002/96/EU), and Annex VII, Section 3 of the WEEE Directive (2012/19/EU).

Section 5: Supplies

- LCD > 100 cm²
- PCBs > 10 cm²
- Printer components containing Brominated flame retardants
- Battery



Figure 5.1: Toner Cartridge

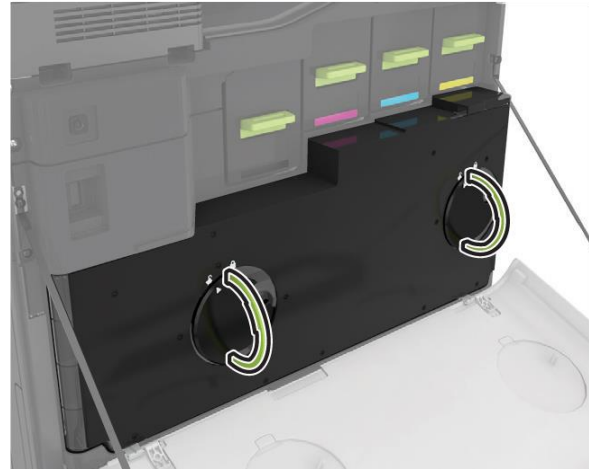

Figure 5.2: Waste toner bottle

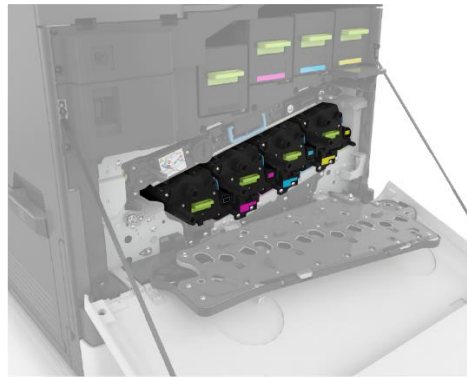

Figure 5.3: Developer Units

Table 5: Supplies – Printed Circuit Boards >10cm² and Plastic with Brominated flame retardants

Item	Description
--	None
Table Component Count (without options)	
LCD>100cm ²	= 0
PCBs>10cm ²	= 0
BFR Plastics	= 0
Battery	= 0

Section 6: Toner cartridge

- LCD > 100 cm²
- PCBs > 10 cm²
- Printer components containing Brominated flame retardants
- Battery



Figure 6.1: Toner Cartridge

Table 6: Toner cartridge - Printed Circuit Boards >10cm² and Plastic with Brominated flame retardants

Item	Description
1	Toner cartridge memory card
Table Component Count (<i>without options</i>)	
LCD>100cm ² = 0	
PCBs>10cm ² = 1	
BFR Plastics = 0	
Battery = 0	

Section 7: Control Panel

- LCD > 100 cm²
- PCBs > 10 cm²
- Printer components containing Brominated flame retardants
- Battery

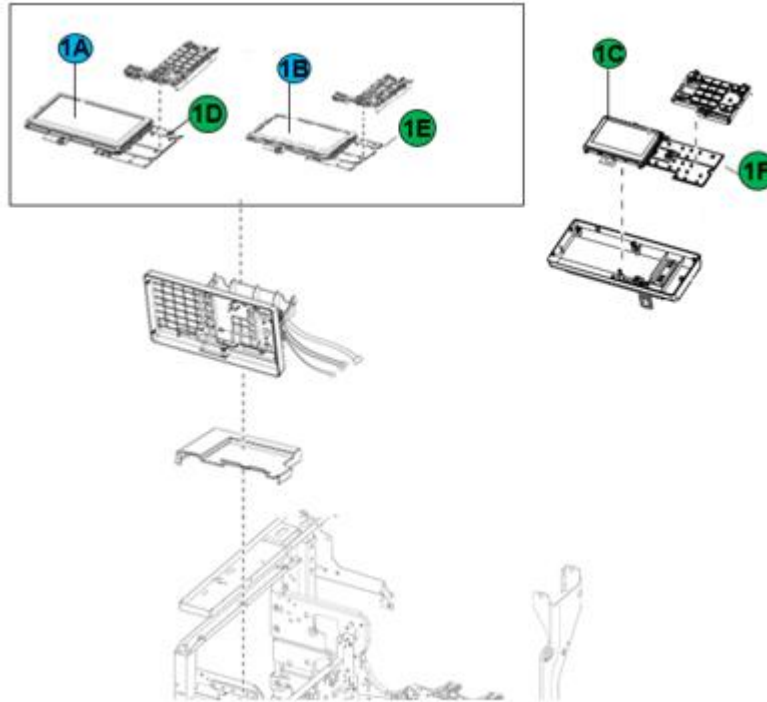

Figure 7.1: Control Panel

Table 7: Control Panel - Printed Circuit Boards >10cm² and Plastic with Brominated flame retardants

Item	Description
1A	10 in. Control panel display assembly
1B	7 in. Control panel display assembly
1C	4.3 in. Control panel display assembly
1D	10 in. Button control panel PCB
1E	7 in. Button control panel PCB
1F	4.3 in Button control panel PCB

Table Component Count (*without options*) Please note there is 1 LCD and 1 Button PCB per model.

LCD>100cm² = 1
 PCBs>10cm² = 1
 BFR Plastics = 0
 Battery = 0

Section 8: Covers

- LCD > 100 cm²
- PCBs > 10 cm²
- Printer components containing Brominated flame retardants
- Battery

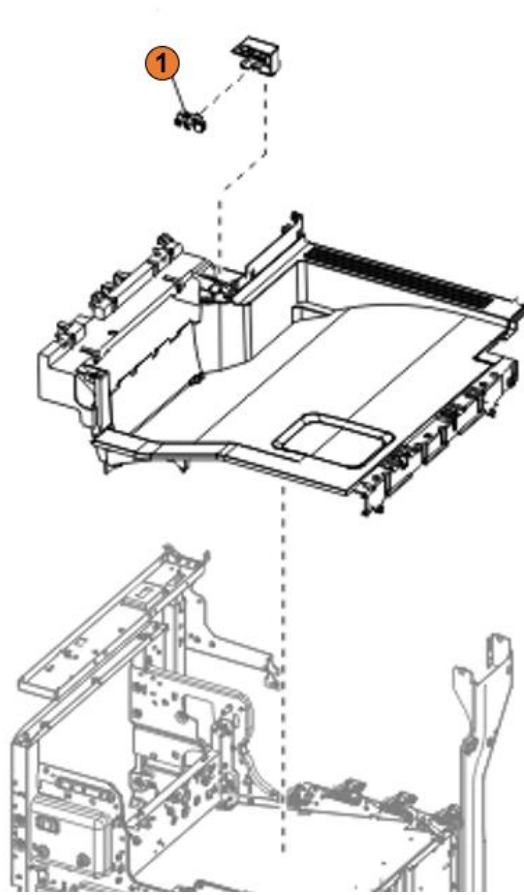

Figure 8.1: Covers

Table 8: Covers - Printed Circuit Boards >10cm² and Brominated Plastic Components

Item	Description
1	Sensor (Bin full)
Table Component Count (without options)	
LCD>100cm ²	= 0
PCBs>10cm ²	= 0
BFR Plastics	= 1
Battery	= 0

Section 9: Imaging Automatic Document Feed (ADF)

- LCD > 100 cm²
- PCBs > 10 cm²
- Printer components containing Brominated flame retardants
- Battery

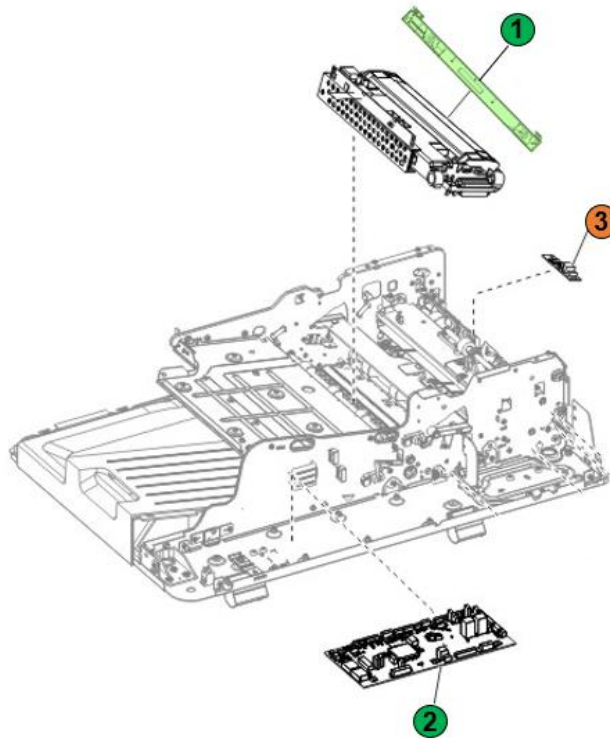

Figure 9.1: Imaging ADF

Table 9: Imaging ADF - Printed Circuit Boards >10cm² and Brominated Plastic Components

Item	Description
1	CCDM, ADF
2	ADF Controller board
3	Sensor (ADF Multifeed receiver)

Table Component Count (*without options*)

LCD>100cm² = 0
 PCBs>10cm² = 2
 BFR Plastics = 1
 Battery = 0

Section 10: ADF 5

- LCD > 100 cm²
- PCBs > 10 cm²
- Printer components containing Brominated flame retardants
- Battery

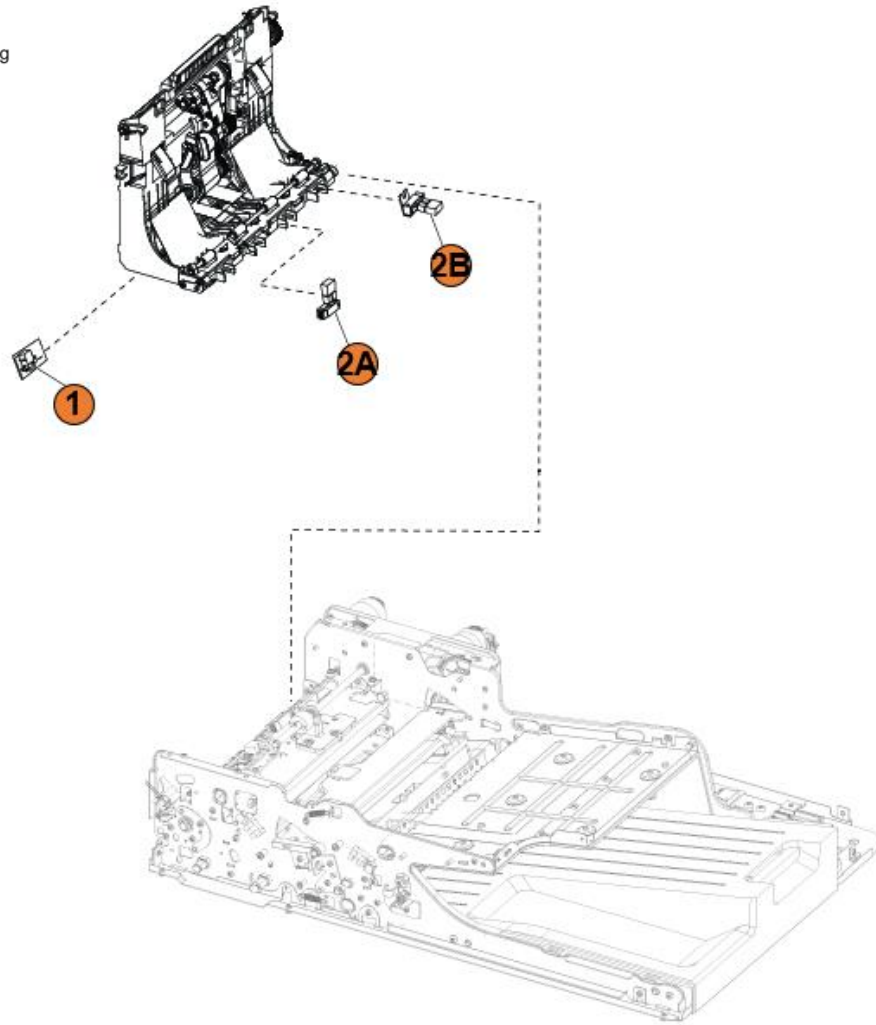

Figure 10.1: ADF 5

Table 10: ADF 5 - Printed Circuit Boards >10cm² and Plastic with Brominated flame retardants

Item	Description
1	Sensor (ADF multifeed transmitter)
2A	Sensor (ADF gap detect)
2B	Sensor (ADF detect)

Table Component Count (*without options*)

LCD>100cm² = 0
 PCBs>10cm² = 0
 BFR Plastics = 3
 Battery = 0

Section 11: ADF 6

- LCD > 100 cm²
- PCBs > 10 cm²
- Printer components containing Brominated flame retardants
- Battery

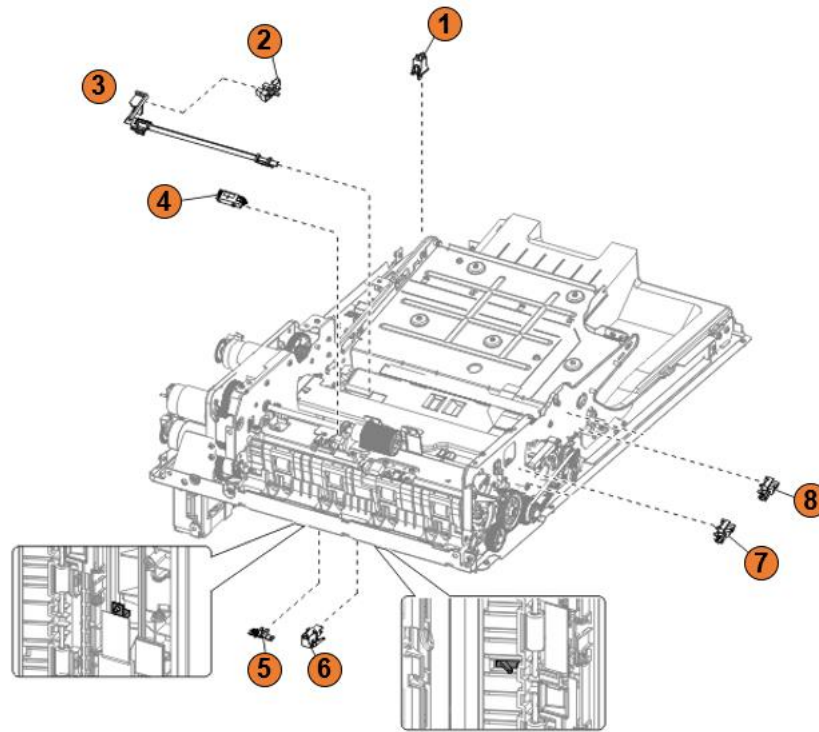

Figure 11.1: ADF 6

Table 11: ADF 6 - Printed Circuit Boards >10cm² and Plastic with Brominated flame retardants

Item	Description
1	Sensor (ADF closed)
2	Sensor (ADF media exit)
3	Sensor (Exit)
4	Sensor (ADF pick)
5	Sensor (ADF 1 st scan)
6	Sensor (ADF 2 nd scan)
7	Sensor (ADF bottom door interlock)
8	Sensor (ADF top door interlock)

Table Component Count (*without options*)

LCD>100cm² = 0
 PCBs>10cm² = 0
 BFR Plastics = 8
 Battery = 0

Section 12: Flatbed scanner 2

- LCD > 100 cm²
- PCBs > 10 cm²
- Printer components containing Brominated flame retardants
- Battery

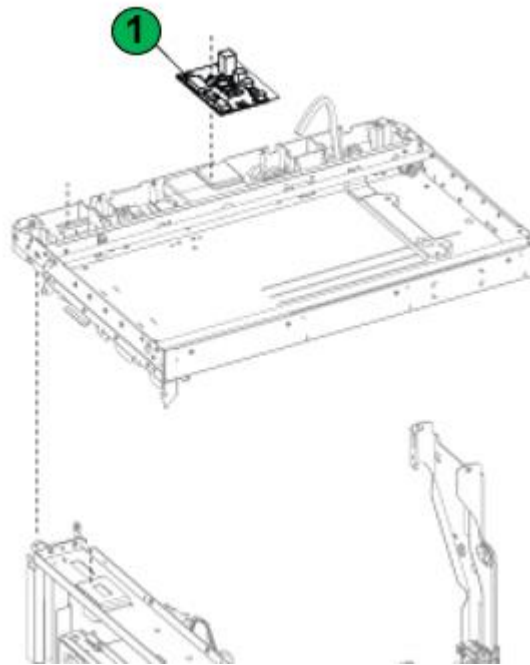

Figure 12.1: Flatbed scanner 2

Table 12: Flatbed scanner 2 - Printed Circuit Boards >10cm² and Plastic with Brominated flame retardants

Item	Description
1	Flatbed scanner board

Table Component Count (*without options*)

LCD>100cm² = 0
 PCBs>10cm² = 1
 BFR Plastics = 0
 Battery = 0

Section 13: Flatbed scanner 3

- LCD > 100 cm²
- PCBs > 10 cm²
- Printer components containing Brominated flame retardants
- Battery

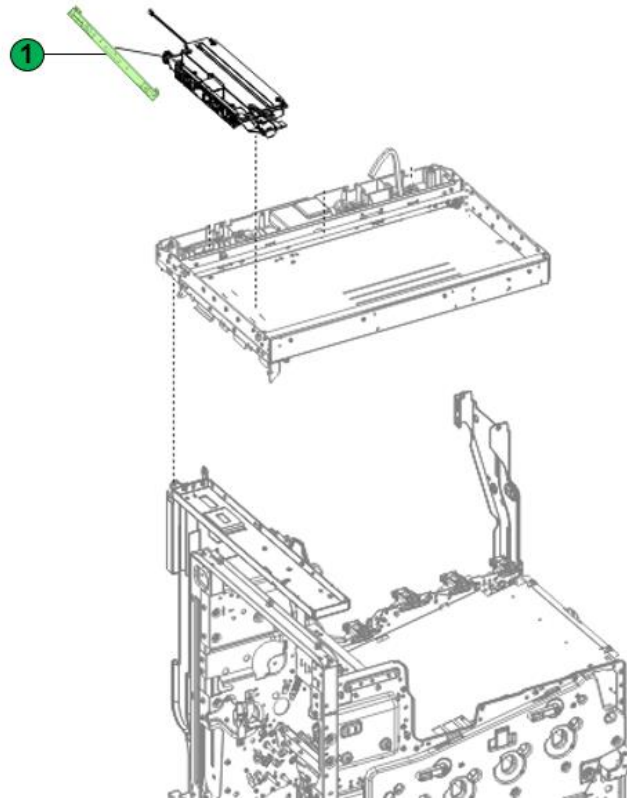

Figure 13.1: Flatbed scanner 3

Table 13: Flatbed scanner 3 - Printed Circuit Boards >10cm² and Plastic with Brominated flame retardants

Item	Description
1	CCDM, flatbed board

Table Component Count (*without options*)

LCD>100cm² = 0
 PCBs>10cm² = 1
 BFR Plastics = 0
 Battery = 0

Section 14: Duplex

- LCD > 100 cm²
- PCBs > 10 cm²
- Printer components containing Brominated flame retardants
- Battery

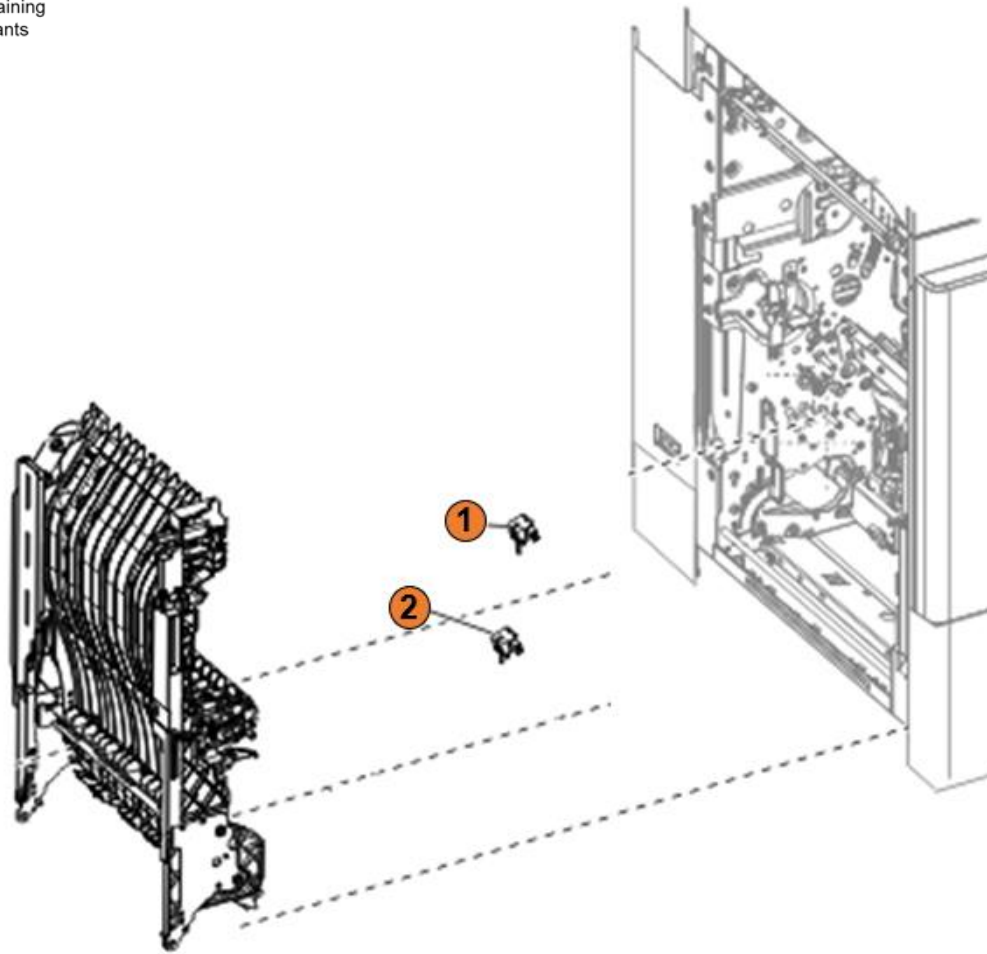

Figure 14.1: Duplex

Table 14: Duplex- Printed Circuit Boards >10cm² and Plastic with Brominated flame retardants

Item	Description
1	Sensor (Duplex path 1)
2	Sensor (Duplex path 2)

Table Component Count (*without options*)

LCD>100cm² = 0
 PCBs>10cm² = 0
 BFR Plastics = 2
 Battery = 0

Section 15: Left door

- LCD > 100 cm²
- PCBs > 10 cm²
- Printer components containing Brominated flame retardants
- Battery

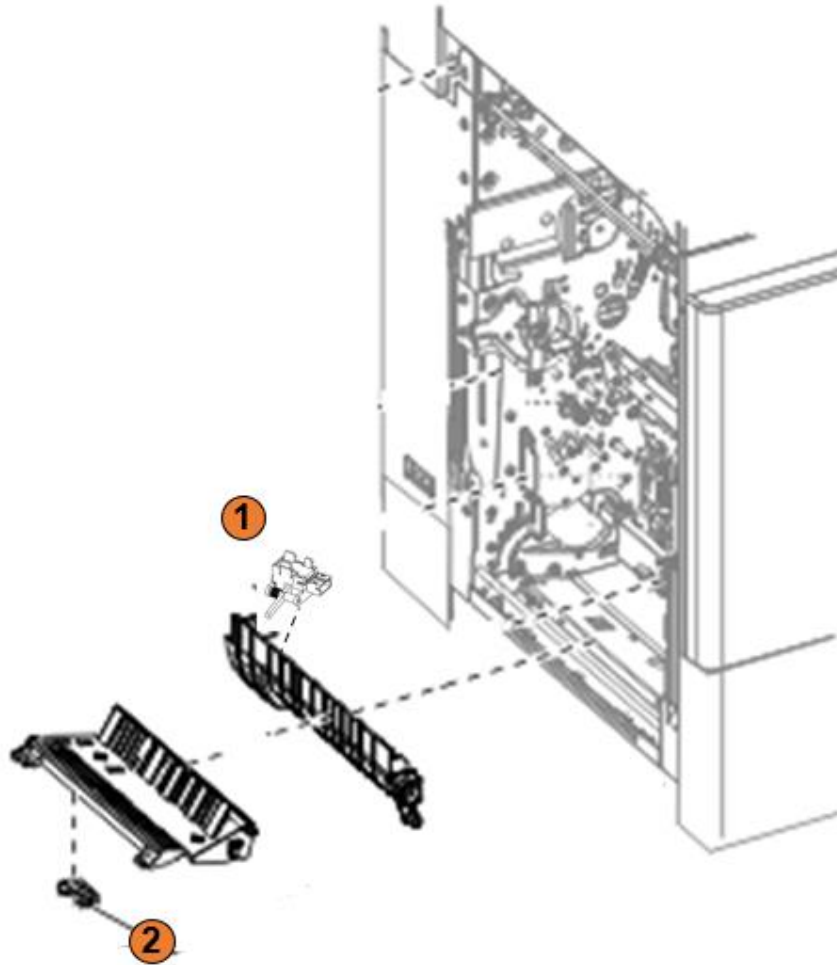

Figure 15.1: Left door

Table 15: Left door- Printed Circuit Boards >10cm² and Plastic with Brominated flame retardants

Item	Description
1	Sensor (pass through)
2	Sensor (paper present)

Table Component Count (without options)

LCD>100cm² = 0
 PCBs>10cm² = 0
 BFR Plastics = 2
 Battery = 0

Section 16: Feeder

- LCD > 100 cm²
- PCBs > 10 cm²
- Printer components containing Brominated flame retardants
- Battery

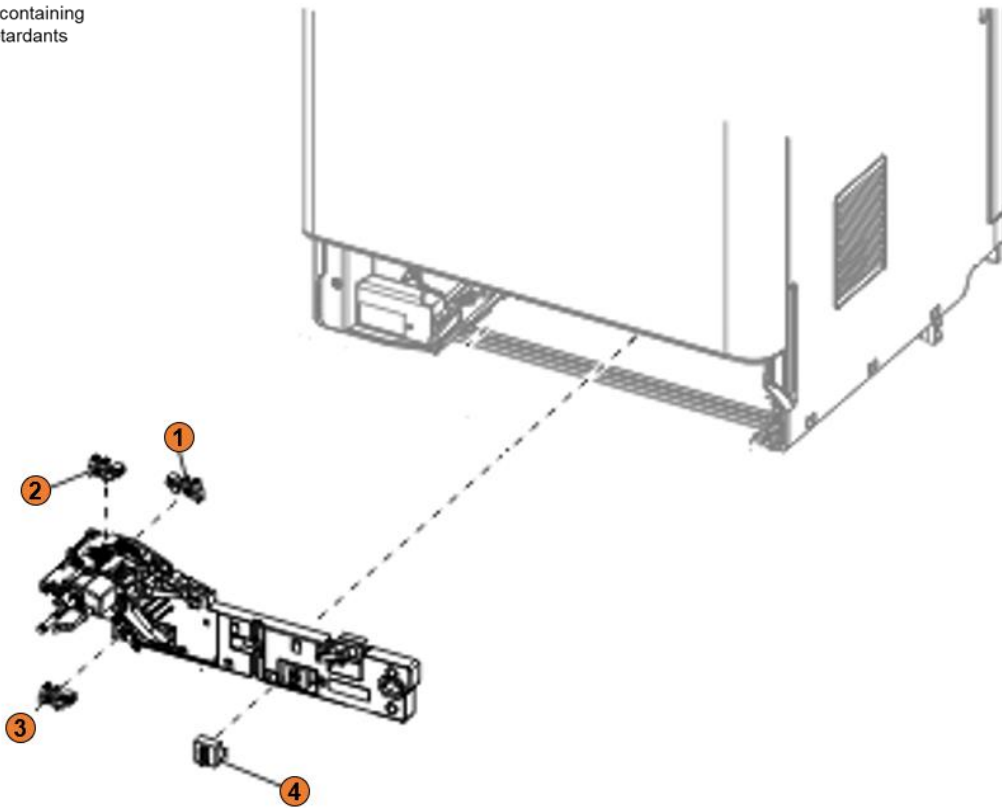

Figure 16.1: Feeder

Table 16: Feeder - Printed Circuit Boards >10cm² and Plastic with Brominated flame retardants

Item	Description
1	Sensor (media out)
2	Sensor (index)
3	Sensor (media low)
4	Sensor (media size)

Table Component Count (without options)

LCD>100cm² = 0
 PCBs>10cm² = 0
 BFR Plastics = 4
 Battery = 0

Section 17: Fuser

- LCD > 100 cm²
- PCBs > 10 cm²
- Printer components containing Brominated flame retardants
- Battery

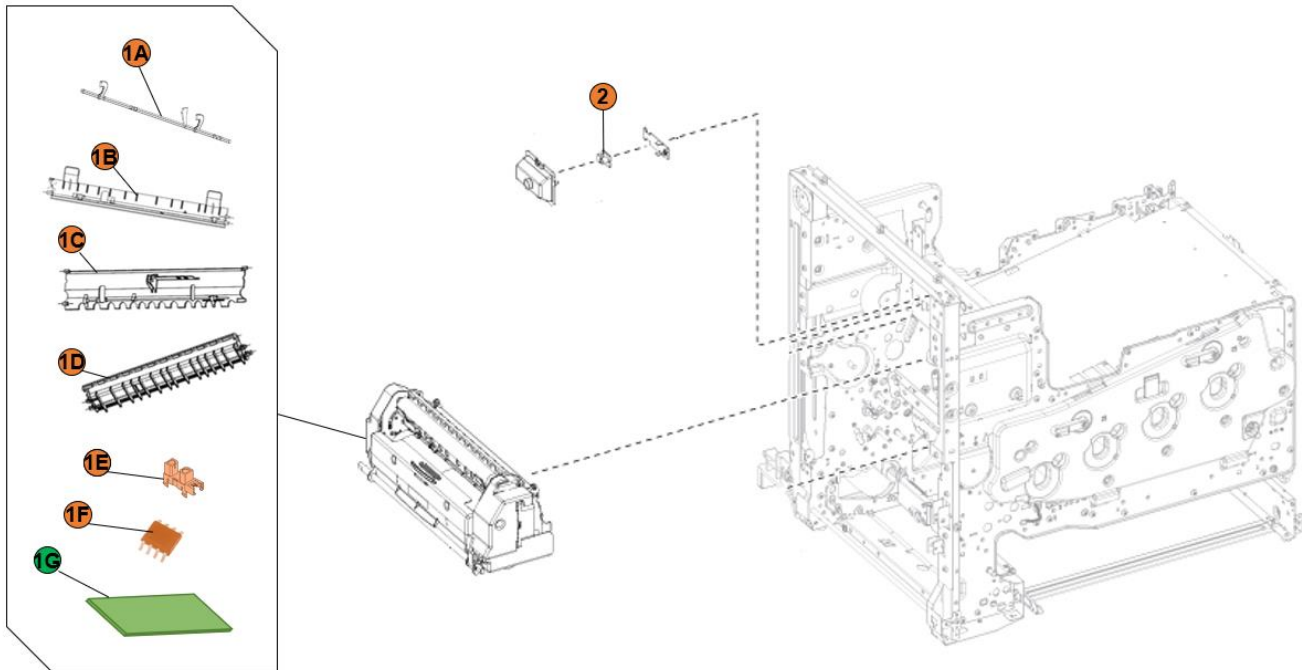

Figure 17.1: Fuser

Table 17: Fuser - Printed Circuit Boards >10cm² and Plastic with Brominated flame retardants

Item	Description
1A	21K1216 - Flag
1B	21K1245 - Guide Exit BUR Side
1C	21K1383 - Guide Exit Belt Side
1D	21K1246 - Entry Fuser
1E	Sensor (Photo)
1F	Sensor (temperature)
1G	Fuser PCBA
2	Sensor (Fuser temperature)

Table Component Count (without options)

LCD>100cm² = 0
 PCBs>10cm² = 1
 BFR Plastics = 7
 Battery = 0

Section 18: Electronics - Front

- LCD > 100 cm²
- PCBs > 10 cm²
- Printer components containing Brominated flame retardants
- Battery

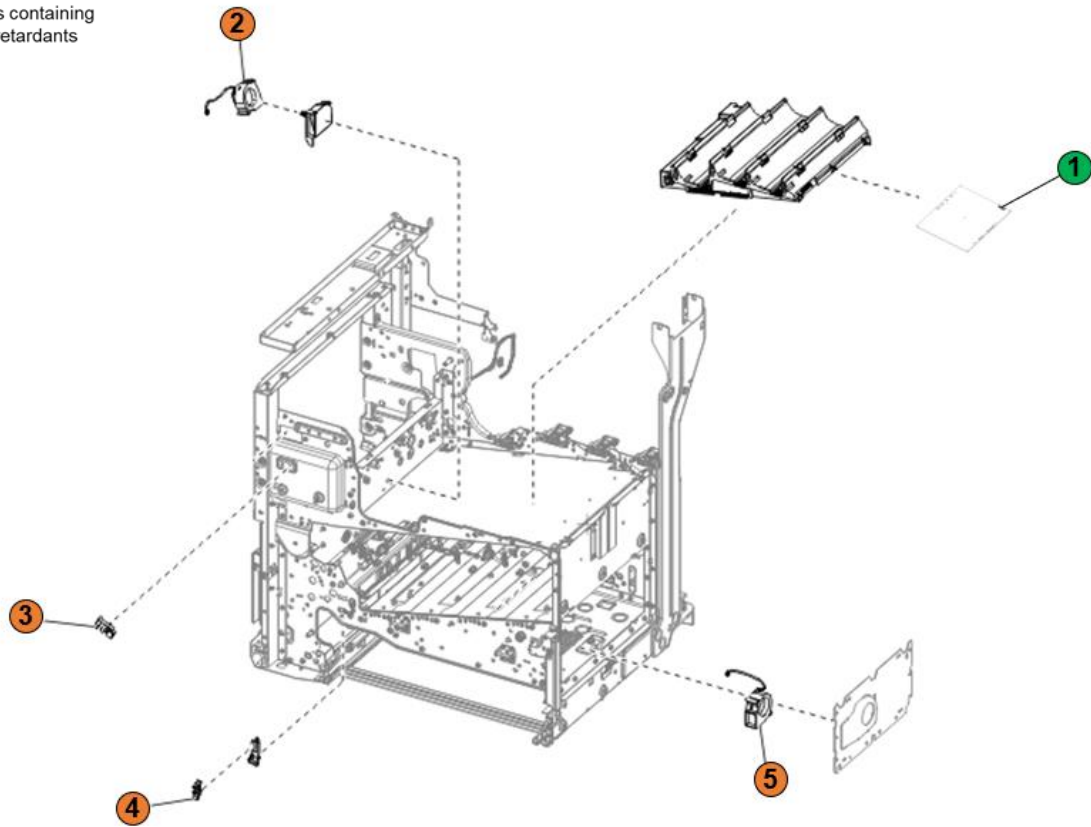

Figure 18.1: Electronics - front

Table 18: Electronics - front - Printed Circuit Boards >10cm² and Plastic with Brominated flame retardants

Item	Description
1	Main HVPS
2	HVPS fan
3	Sensor (waste toner bottle present)
4	Sensor (Door interlock)
5	Printhead fan

Table Component Count (*without options*)

LCD>100cm² = 0
 PCBs>10cm² = 1
 BFR Plastics = 4
 Battery = 0

Section 19: Electronics - Rear

- LCD > 100 cm²
- PCBs > 10 cm²
- Printer components containing Brominated flame retardants
- Battery

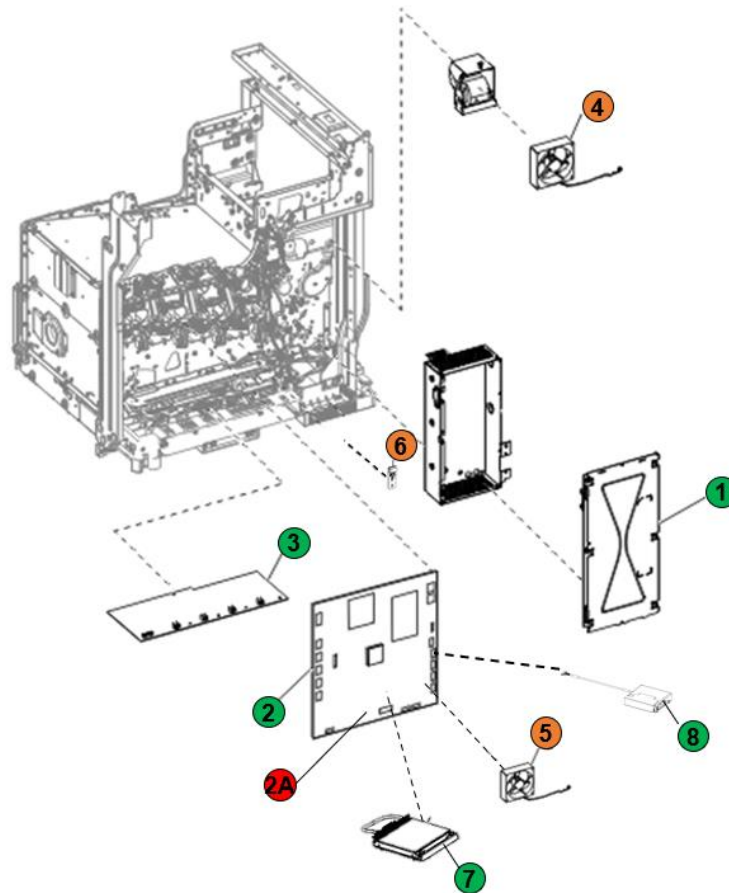

Figure 19.1: Electronics -Rear

Table 19: Electronics - Rear - Printed Circuit Boards >10cm² and Plastic with Brominated flame retardants

Item	Description
1	LVPS
2	Controller board
2A	Battery
3	Charge roller HVPS
4	Main fan
5	Controller board fan
6	Sensor (weather station)
7	Hard drive
8	Fax card

Table Component Count (without options)

LCD>100cm² = 0
 PCBs>10cm² = 5
 BFR Plastics = 3
 Battery = 1

Section 20: Registration

- LCD > 100 cm²
- PCBs > 10 cm²
- Printer components containing Brominated flame retardants
- Battery

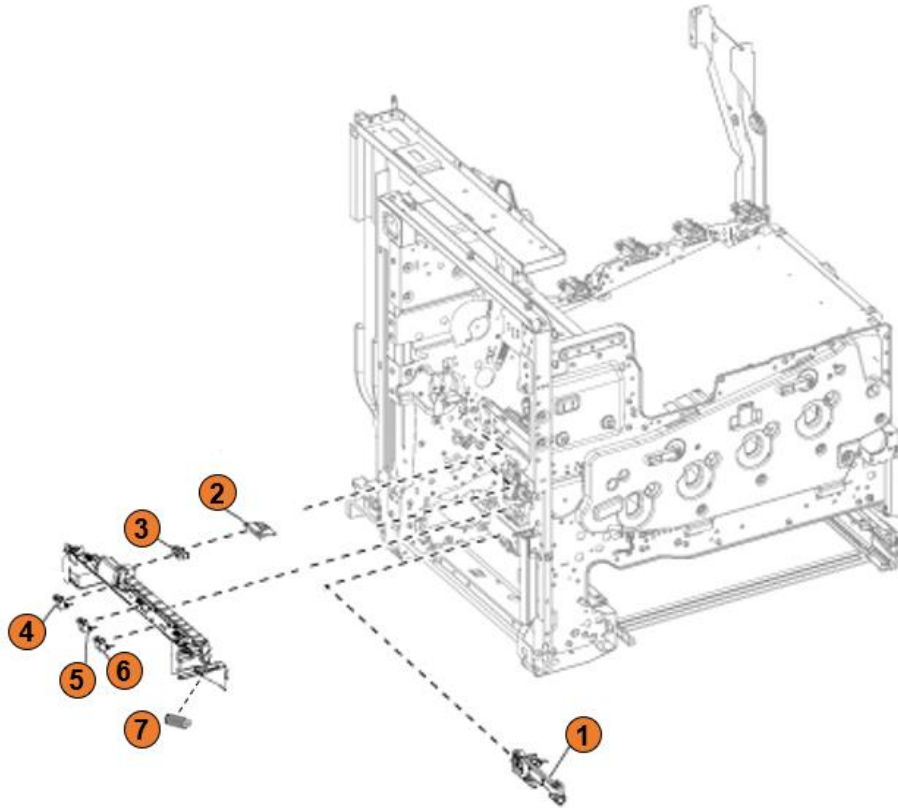

Figure 20.1: Registration

Table 20: Registration - Printed Circuit Boards >10cm² and Plastic with Brominated flame retardants

Item	Description
1	Sensor (Input)
2	Sensor (Aperture)
3	Sensor (Deskew roller exit)
4	Sensor (Deskew roller entry)
5	Sensor (Narrow media)
6	Sensor (Near narrow media)
7	Sensor (photo)

Table Component Count (without options)

LCD>100cm² = 0
 PCBs>10cm² = 0
 BFR Plastics = 7
 Battery = 0

Section 21: Motors

- LCD > 100 cm²
- PCBs > 10 cm²
- Printer components containing Brominated flame retardants
- Battery

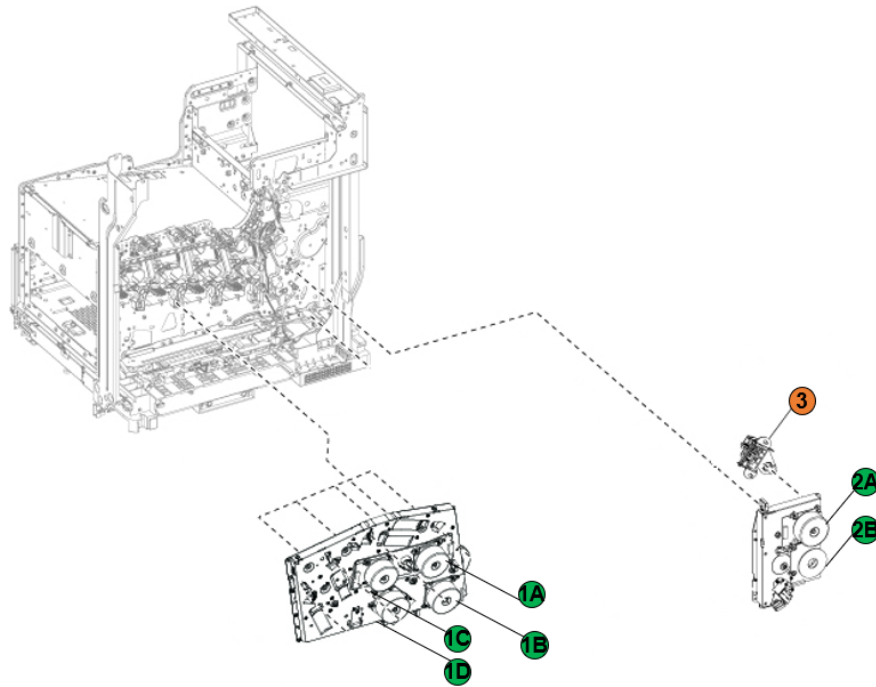

Figure 21.1: Motors

Table 21: Motors- Printed Circuit Boards >10cm² and Plastic with Brominated flame retardants

Item	Description
1A	EP developer toner gearbox 1
1B	EP developer toner gearbox 2
1C	EP developer toner gearbox 3
1D	EP developer toner gearbox 4
2A	Fuser/ transfer belt gearbox 1
2B	Fuser/ transfer belt gearbox 2
3	Sensor (waste toner full)

Table Component Count (without options)

LCD>100cm² = 0
 PCBs>10cm² = 6
 BFR Plastics = 1
 Battery = 0

Section 22: Printhead

- LCD > 100 cm²
- PCBs > 10 cm²
- Printer components containing Brominated flame retardants
- Battery

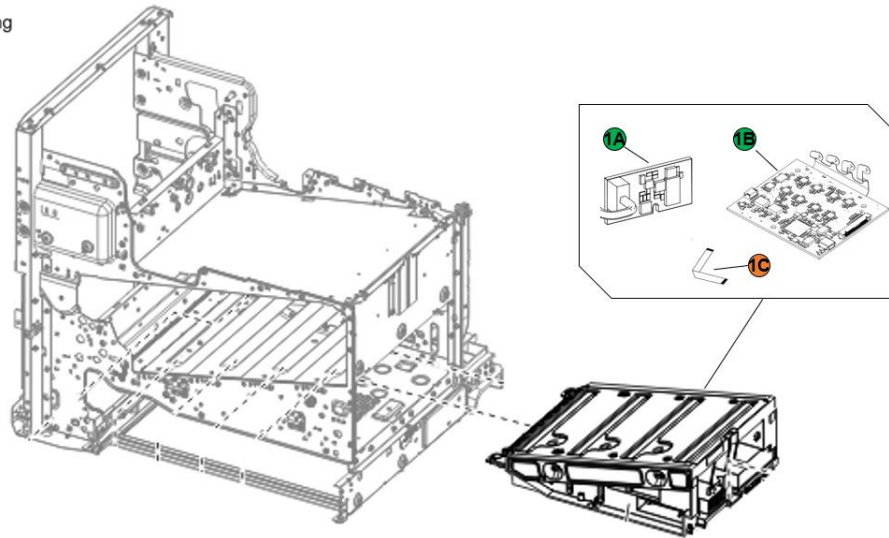

Figure 22.1: Printhead

Table 22: Printhead- Printed Circuit Boards >10cm² and Plastic with Brominated flame retardants

Item	Description
1A	Hsync card
1B	LD card
1C	Printhead tape

Table Component Count (*without options*)

LCD>100cm² = 0
 PCBs>10cm² = 2
 BFR Plastics = 1
 Battery = 0

Section 23: Toner supply

- LCD > 100 cm²
- PCBs > 10 cm²
- Printer components containing Brominated flame retardants
- Battery

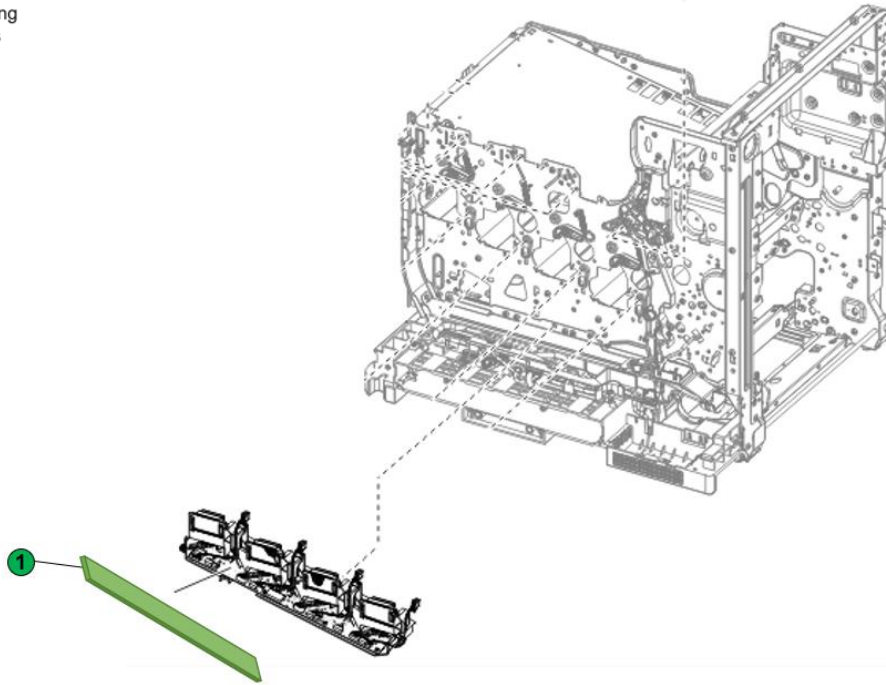

Figure 23.1: Toner Supply

Table 23: Toner Supply- Printed Circuit Boards >10cm² and Plastic with Brominated flame retardants

Item	Description
1	Smart chip interface board
Table Component Count <i>(without options)</i>	
LCD>100cm ²	= 0
PCBs>10cm ²	= 1
BFR Plastics	= 0
Battery	= 0

Section 24: Redrive

- LCD > 100 cm²
- PCBs > 10 cm²
- Printer components containing Brominated flame retardants
- Battery

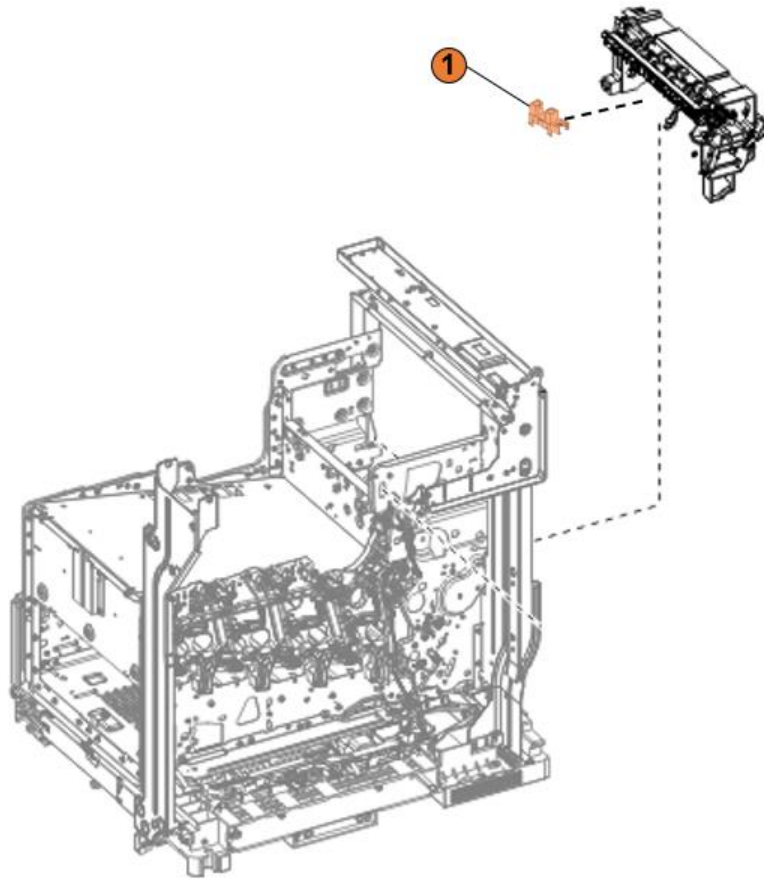

Figure 24.1: Redrive

Table 24: Redrive- Printed Circuit Boards >10cm² and Plastic with Brominated flame retardants

Item	Description
1	Sensor (Photo)
Table Component Count (<i>without options</i>)	
LCD>100cm ²	= 0
PCBs>10cm ²	= 0
BFR Plastics	= 1
Battery	= 0

Section 25: Transfer- Front

- LCD > 100 cm²
- PCBs > 10 cm²
- Printer components containing Brominated flame retardants
- Battery

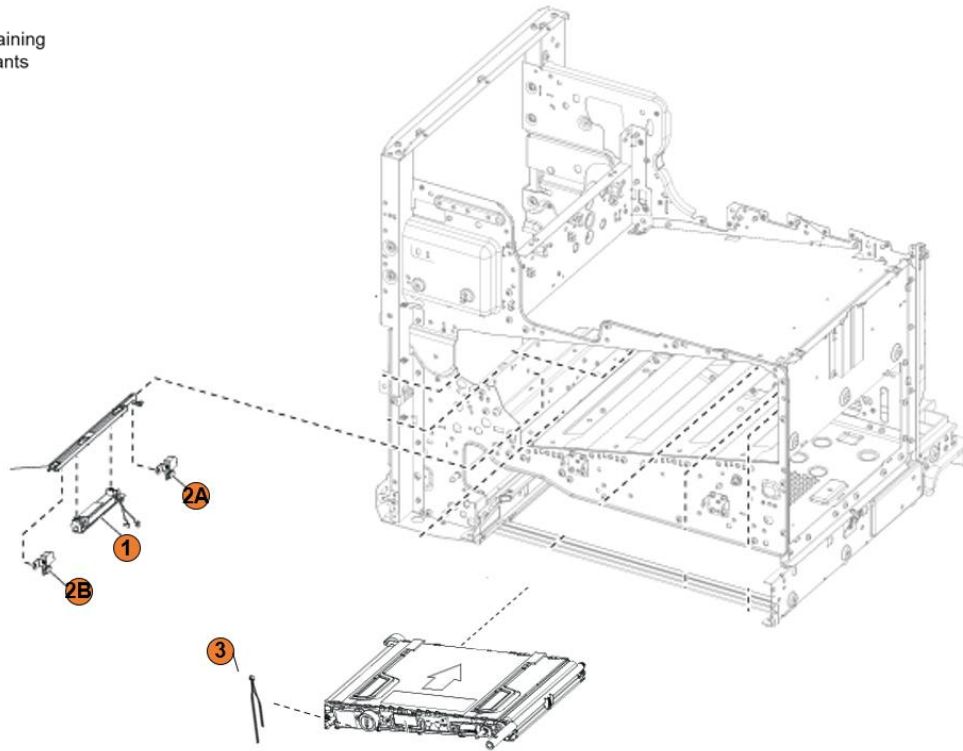

Figure 25.1: Transfer- Front

Table 25: Transfer- Front- Printed Circuit Boards >10cm² and Plastic with Brominated flame retardants

Item	Description
1	Sensor (TPS)
2A	Sensor (Auto alignment)
2B	Sensor (Auto alignment)
3	Sensor (Drive roll)

Table Component Count (*without options*)

LCD>100cm² = 0
 PCBs>10cm² = 0
 BFR Plastics = 4
 Battery = 0

Section 26: For Reference Only (Customer Replaceable Paper handling devices)

- LCD > 100 cm²
- PCBs > 10 cm²
- Printer components containing Brominated flame retardants
- Battery

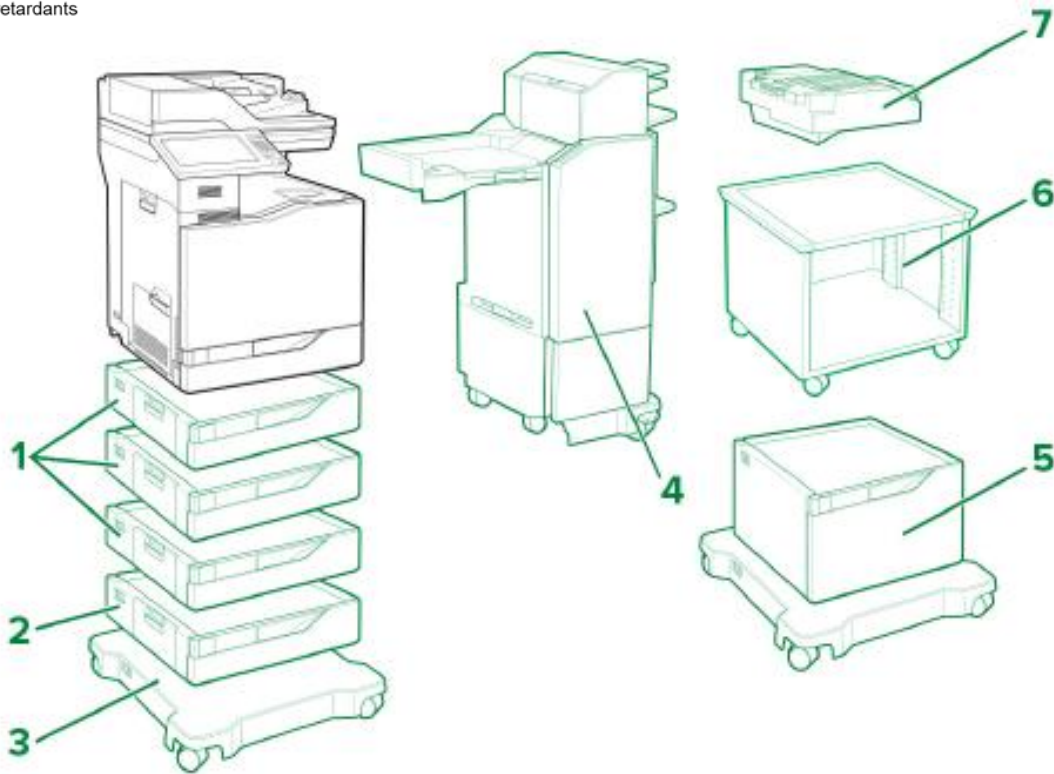

Figure 26.1: Customer Replaceable Paper Handling Devices

Table 26: For Reference Only (Customer Replaceable Paper Handling Devices)

Item	Description
1	550-sheet tray
2	Envelope tray
3	Caster base*
4	Multiposition stapler, hole punch finisher short/ tall
5	2200-sheet tray
6	Adjustable print stand*
7	Staple finisher
Options marked with (*) are non-Electrical and electronic units	

Section 27: Paper Handling Options 550 Sheet / Envelope Tray Rear

- LCD > 100 cm²
- PCBs > 10 cm²
- Printer components containing Brominated flame retardants
- Battery

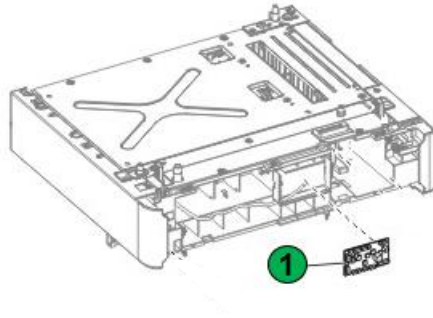

Figure 27.1: Paper Handling Options 550 Sheet / Envelope Tray Rear

Table 27: Paper Handling Options 550 Sheet / Envelope Tray Rear - Printed Circuit Boards >10cm² and Plastic with Brominated flame retardants

Item	Description
1	550-sheet tray controller board
Table Component Count (without options)	
LCD>100cm ²	= 0
PCBs>10cm ²	= 0
BFR Plastics	= 0
Battery	= 0

Section 28: Paper Handling Options –550 Sheet/ Envelope Tray Front

- LCD > 100 cm²
- PCBs > 10 cm²
- Printer components containing Brominated flame retardants
- Battery

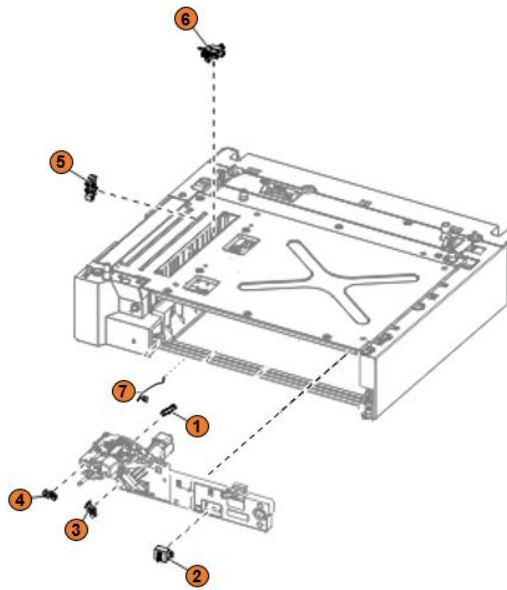

Figure 28.1: Paper Handling Options – 550 Sheet/ Envelope Tray Front

Table 28: Paper Handling Options – 550 Sheet/ Envelope Tray Front – Printed Circuit Boards >10cm² and Plastic with Brominated flame retardants

Item	Description
1	Sensor (media out)
2	Sensor (media size)
3	Sensor (media low)
4	Sensor (index)
5	Sensor (Jam door)
6	Sensor (Passthrough)
7	Sensor (Wake up)

Table Component Count (*without options*)

LCD>100cm² = 0
 PCBs>10cm² = 0
 BFR Plastics = 0
 Battery = 0

Section 29: Paper Handling Options – 2200 Sheet Tray Rear

- LCD > 100 cm²
- PCBs > 10 cm²
- Printer components containing Brominated flame retardants
- Battery

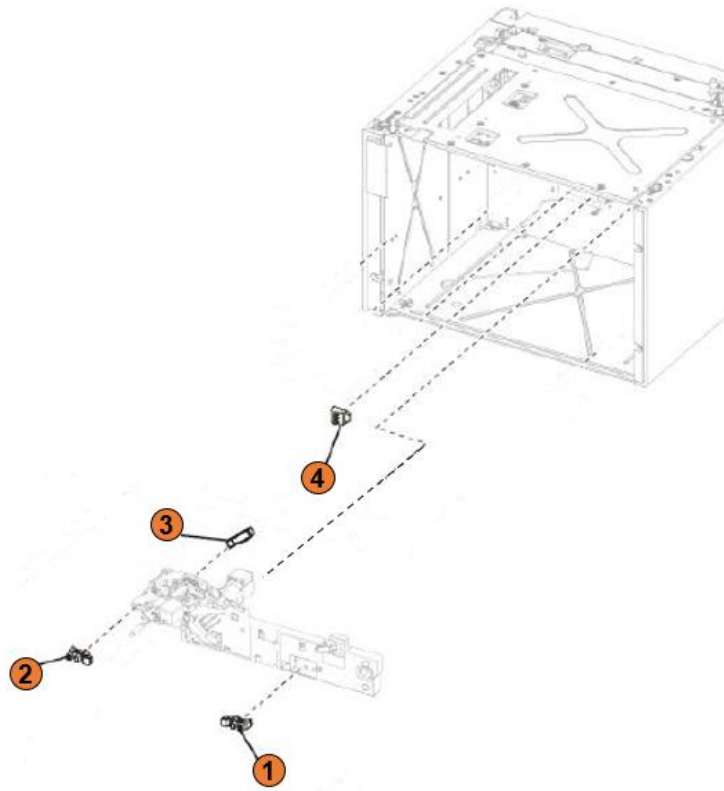

Figure 29.1: Paper Handling Options – 2200 Sheet Tray Rear

Table 29 Paper Handling Options – 2200 Sheet Tray Rear – Printed Circuit Boards >10cm² and Plastic with Brominated flame retardants

Item	Description
1	Sensor (media low)
2	Sensor (index)
3	Sensor (media out)
4	Sensor (media size)

Table Component Count (*without options*)

LCD>100cm² = 0
 PCBs>10cm² = 0
 BFR Plastics = 0
 Battery = 0

Section 30: Paper Handling Options 550 – 2200 Sheet / Envelope Tray Rear

- LCD > 100 cm²
- PCBs > 10 cm²
- Printer components containing Brominated flame retardants
- Battery

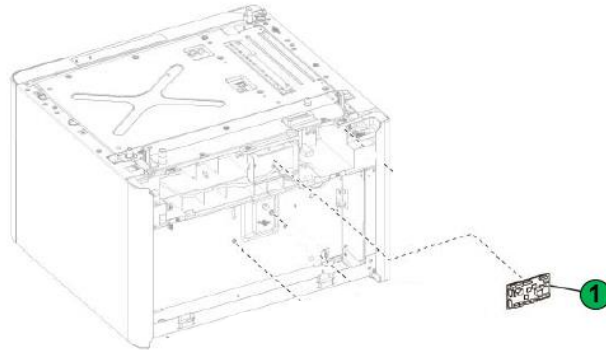

Figure 30.1: Paper Handling Options 550– 2200 Sheet / Envelope Tray Rear

Table 30: Paper Handling Options 550 – 2200 Sheet / Envelope Tray Rear - Printed Circuit Boards >10cm² and Plastic with Brominated flame retardants

Item	Description
1	550-sheet tray controller board Controller board
Table Component Count (<i>without options</i>)	
LCD>100cm ²	= 0
PCBs>10cm ²	= 0
BFR Plastics	= 0
Battery	= 0

Section 31: Paper Handling Options – Staple Finisher Front

- LCD > 100 cm²
- PCBs > 10 cm²
- Printer components containing Brominated flame retardants
- Battery

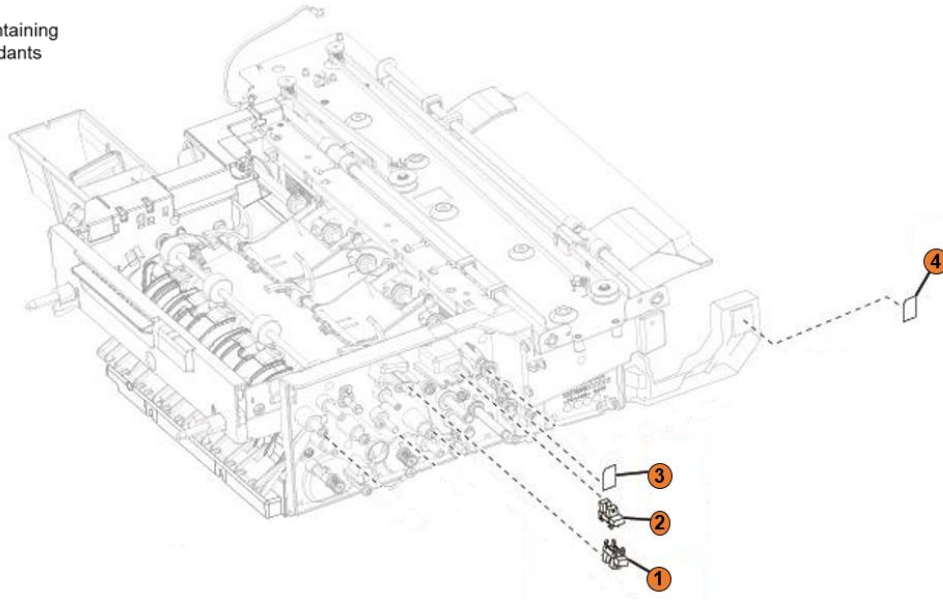

Figure 31.1: Paper Handling Options– Staple Finisher Front

Table 31: Paper Handling – Staple Finisher Front - Printed Circuit Boards >10cm² and Plastic with Brominated flame retardants

Item	Description
1	Sensor (aligner)
2	Sensor (exit)
3	Sensor (lower bin full)
4	Sensor (upper bin full)

Table Component Count (*without options*)

LCD>100cm² = 0
 PCBs>10cm² = 0
 BFR Plastics = 0
 Battery = 0

Section 32: Paper Handling Options – Staple Finisher Electrical

- LCD > 100 cm²
- PCBs > 10 cm²
- Printer components containing Brominated flame retardants
- Battery

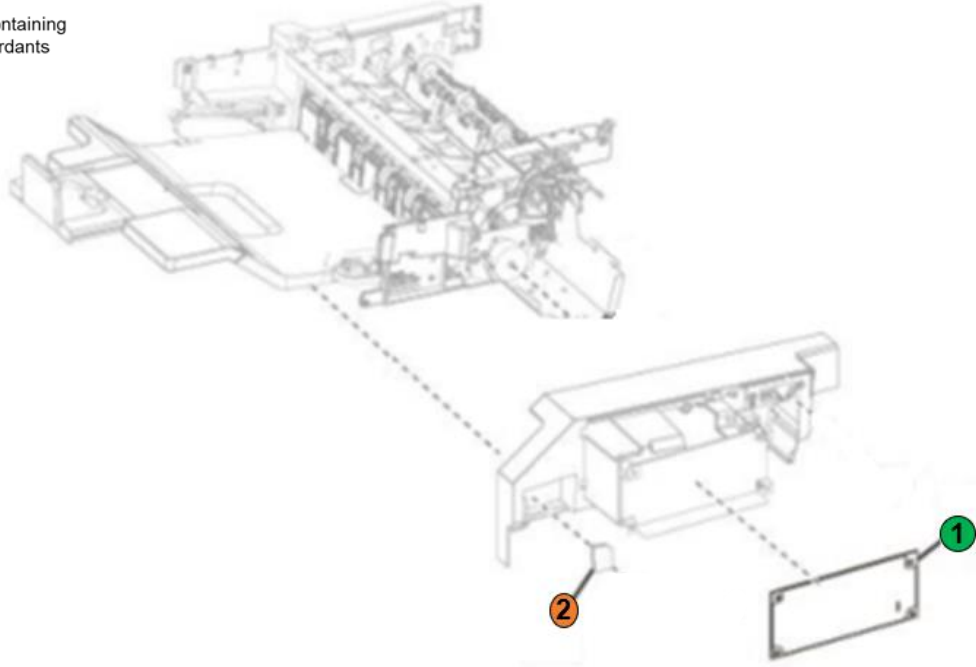

Figure 32.1: Paper Handling Options – Staple Finisher Electrical

Table 32: Paper Handling Options 550 Sheet / Envelope Tray Rear - Printed Circuit Boards >10cm² and Plastic with Brominated flame retardants

Item	Description
1	Finisher controller board
2	Sensor (Bin full)

Table Component Count (*without options*)

LCD>100cm² = 0
 PCBs>10cm² = 0
 BFR Plastics = 0
 Battery = 0

Section 33: Paper Handling Options – Staple Finisher Rear

- LCD > 100 cm²
- PCBs > 10 cm²
- Printer components containing Brominated flame retardants
- Battery

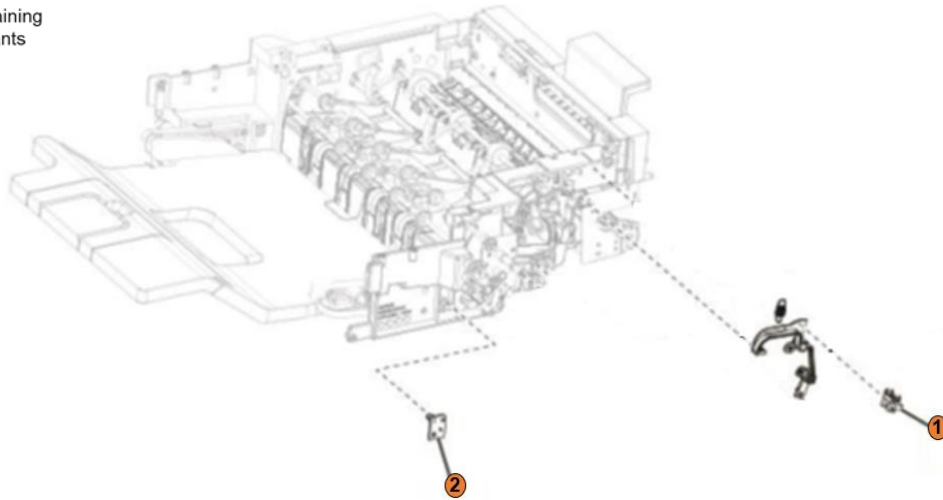

Figure 33.1: Paper Handling Options – Staple Finisher Rear

Table 33: Paper Handling Options – Staple Finisher Rear - Printed Circuit Boards >10cm² and Plastic with Brominated flame retardants

Item	Description
1	Sensor (slack)
2	Sensor (bin full)

Table Component Count (*without options*)

LCD>100cm² = 0
 PCBs>10cm² = 0
 BFR Plastics = 0
 Battery = 0

Section 34: Paper Handling Options – Staple Finisher Tamper

- LCD > 100 cm²
- PCBs > 10 cm²
- Printer components containing Brominated flame retardants
- Battery

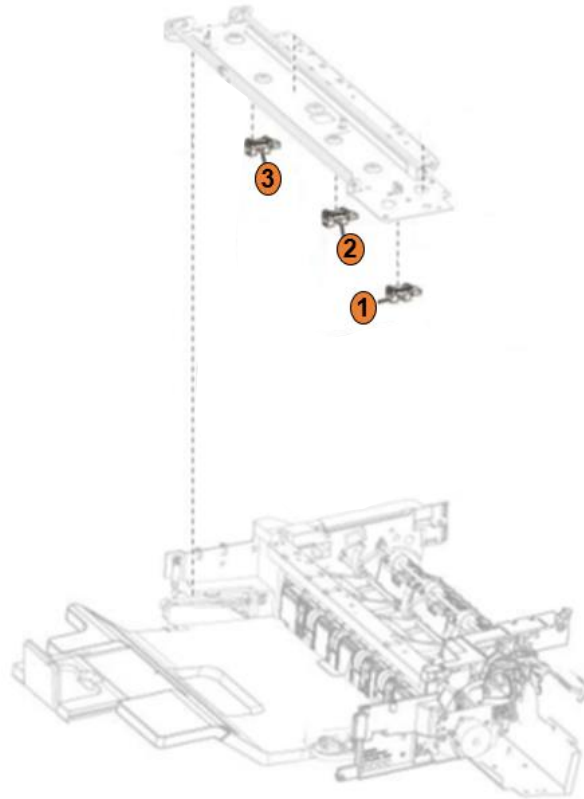

Figure 34.1: Paper Handling Options – Staple Finisher Tamper

Table 34: Paper Handling Options – Staple Finisher Tamper - Printed Circuit Boards >10cm² and Plastic with Brominated flame retardants

Item	Description
1	Sensor (rear)
2	Sensor (narrow media)
3	Sensor (front)

Table Component Count (*without options*)

LCD>100cm² = 0
 PCBs>10cm² = 0
 BFR Plastics = 0
 Battery = 0

Section 35: Paper Handling Options – MSHPF electronics

- LCD > 100 cm²
- PCBs > 10 cm²
- Printer components containing Brominated flame retardants
- Battery

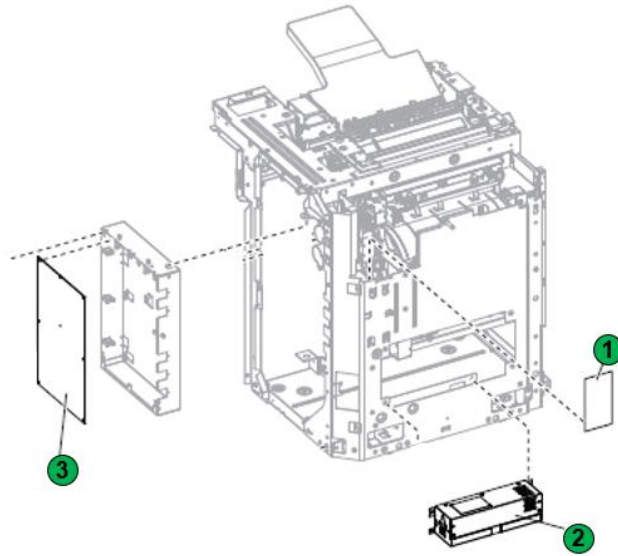

Figure 35.1: Paper Handling Options – MSHPF electronics

Table 35: Paper Handling Options – MSHPF electronics - Printed Circuit Boards >10cm² and Plastic with Brominated flame retardants

Item	Description
1	Mid-transport interface board
2	MSHPF power supply
3	MSHPF controller board

Table Component Count (*without options*)

LCD>100cm² = 0
 PCBs>10cm² = 0
 BFR Plastics = 0
 Battery = 0

Section 36: Paper Handling Options – MSHPF compiler

- LCD > 100 cm²
- PCBs > 10 cm²
- Printer components containing Brominated flame retardants
- Battery

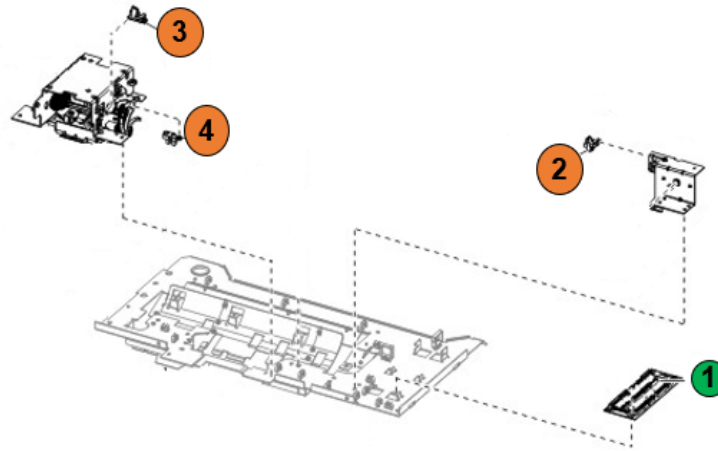

Figure 36.1 Paper Handling Options – MSHPF compiler

Table 36: Paper Handling Options – MSHPF compiler - Printed Circuit Boards >10cm² and Plastic with Brominated flame retardants

Item	Description
1	Compiler interface board
2	Sensor (stack height)
3	Sensor (exit cam)
4	Sensor (paddle)

Table Component Count (*without options*)

LCD>100cm² = 0
 PCBs>10cm² = 0
 BFR Plastics = 0
 Battery = 0

Section 37: Paper Handling Options – HPT electronics

- LCD > 100 cm²
- PCBs > 10 cm²
- Printer components containing Brominated flame retardants
- Battery

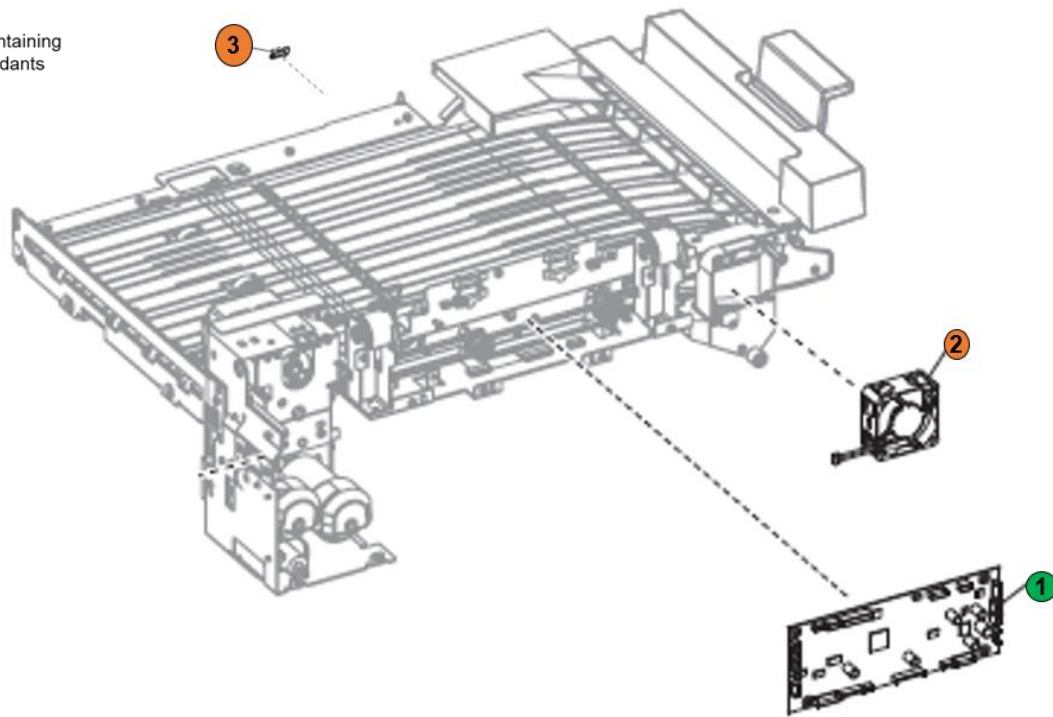

Figure 37. Paper Handling Options – HPT electronics

Table 37: Paper Handling Options – HPT electronics - Printed Circuit Boards >10cm² and Plastic with Brominated flame retardants

Item	Description
1	Fan
2	HPT controller board
3	Sensor (jam cover)

Table Component Count (*without options*)

LCD>100cm² = 0
 PCBs>10cm² = 0
 BFR Plastics = 0
 Battery = 0

Section 38: Paper Handling Options – Mailbox

- LCD > 100 cm²
- PCBs > 10 cm²
- Printer components containing Brominated flame retardants
- Battery

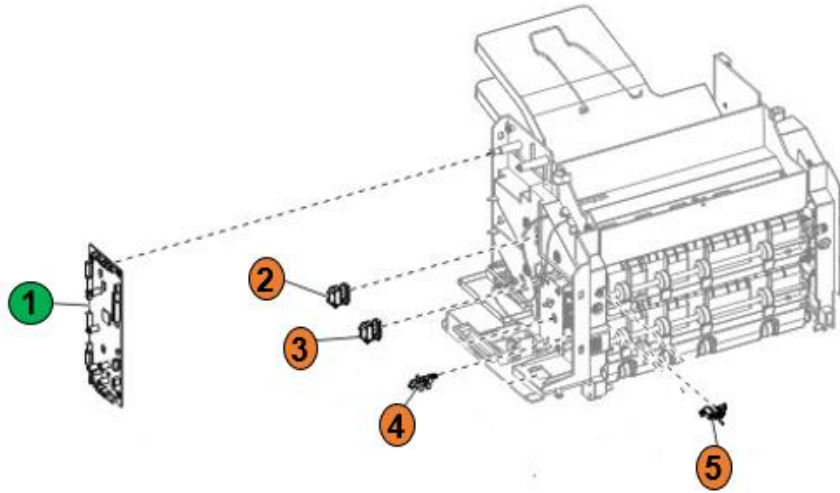

Figure 38.1 Paper Handling Options – Mailbox

Table 38: Paper Handling Options – Mailbox - Printed Circuit Boards >10cm² and Plastic with Brominated flame retardants

Item	Description
1	Mailbox controller board
2	Sensor (Jam door)
3	Sensor (bin 1 full)
4	Sensor (Bin 2 full)
5	Sensor (Transport)

Table Component Count (*without options*)

LCD>100cm² = 0
 PCBs>10cm² = 0
 BFR Plastics = 0
 Battery = 0

Section 39: Mailbox 4

- LCD > 100 cm²
- PCBs > 10 cm²
- Printer components containing Brominated flame retardants
- Battery

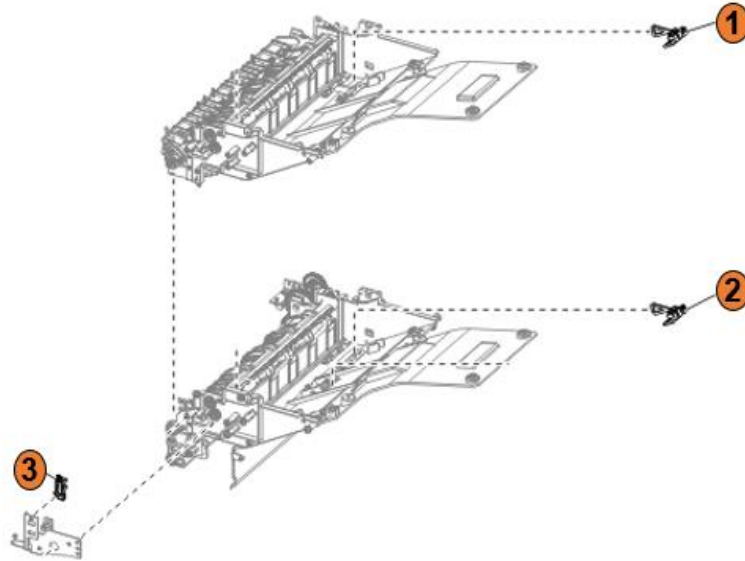

Figure 39.1 Mailbox 4

Table 39: Mailbox 4 - Printed Circuit Boards >10cm² and Plastic with Brominated flame retardants

Item	Description
1	Sensor (paper present)
2	Sensor (Paper present)
3	Sensor (Diverter)

Table Component Count (*without options*)

LCD>100cm² = 0
 PCBs>10cm² = 0
 BFR Plastics = 0
 Battery = 0

Section 40: HPT Sensors

- LCD > 100 cm²
- PCBs > 10 cm²
- Printer components containing Brominated flame retardants
- Battery

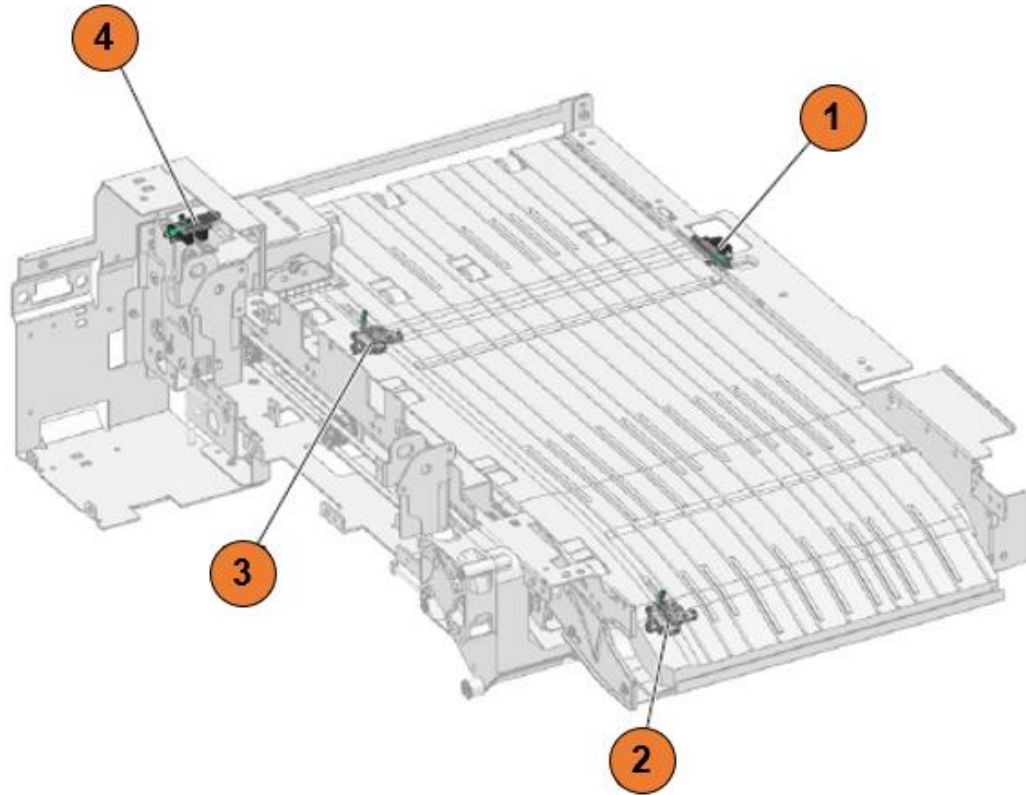

Figure 40.1 HPT Sensors

Table 40: HPT Sensors - Printed Circuit Boards >10cm² and Plastic with Brominated flame retardants

Item	Description
1	Sensor (jam cover)
2	Sensor (transport)
3	Sensor (entrance)
4	Sensor (HPT)

Table Component Count (*without options*)

LCD>100cm² = 0
 PCBs>10cm² = 0
 BFR Plastics = 0
 Battery = 0

Section 41: MSHPF mid transport drive

- LCD > 100 cm²
- PCBs > 10 cm²
- Printer components containing Brominated flame retardants
- Battery

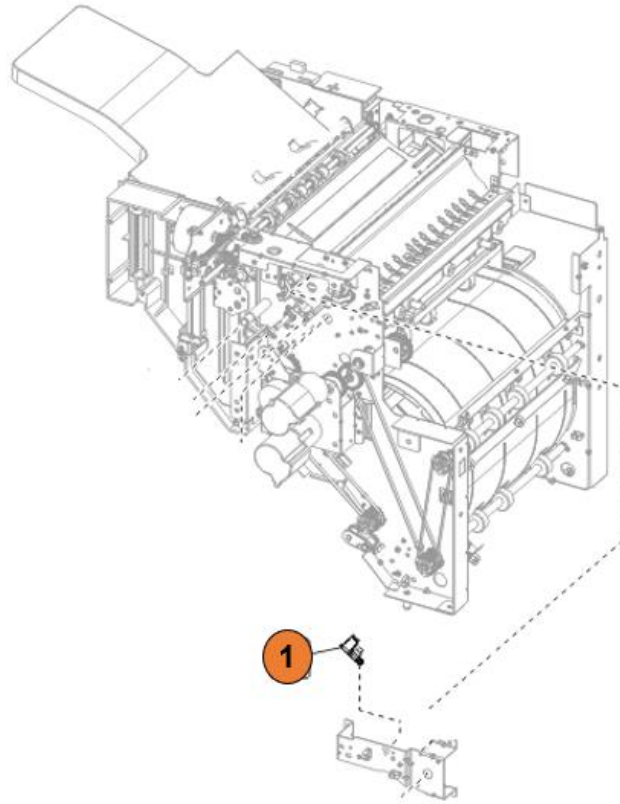

Figure 41.1 MSHPF mid-transport drive

Table 41: MSHPF mid-transport drive - Printed Circuit Boards >10cm² and Plastic with Brominated flame retardants

Item	Description
1	Sensor (diverter)

Table Component Count (*without options*)

LCD>100cm² = 0
 PCBs>10cm² = 0
 BFR Plastics = 0
 Battery = 0

Section 42: MSHPF mid transport paper path

- LCD > 100 cm²
- PCBs > 10 cm²
- Printer components containing Brominated flame retardants
- Battery

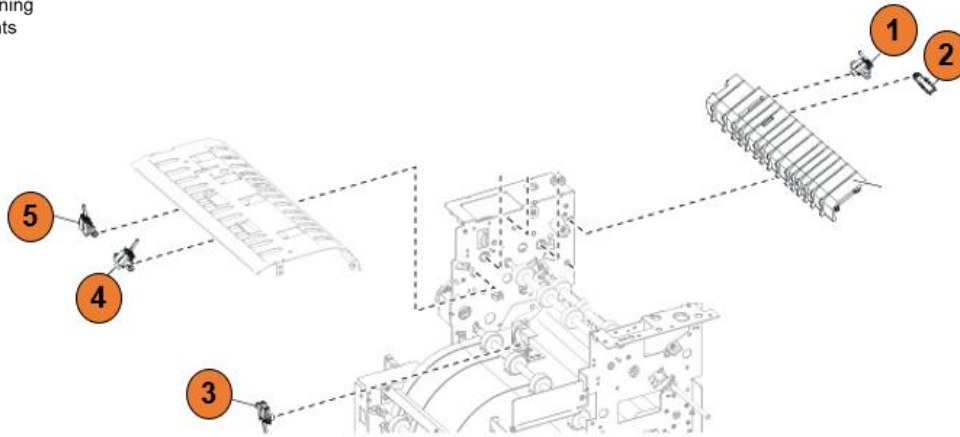

Figure 42.1 MSHPF mid-transport paper path

Table 42: MSHPF mid-transport paper path - Printed Circuit Boards >10cm² and Plastic with Brominated flame retardants

Item	Description
1	Sensor (exit)
2	Sensor (interlock)
3	Sensor (staging outer)
4	Sensor (staging entrance)
5	Sensor (mid-transport)

Table Component Count (*without options*)

LCD>100cm² = 0
 PCBs>10cm² = 0
 BFR Plastics = 0
 Battery = 0

Section 43: MSHPF offset drive

- LCD > 100 cm²
- PCBs > 10 cm²
- Printer components containing Brominated flame retardants
- Battery

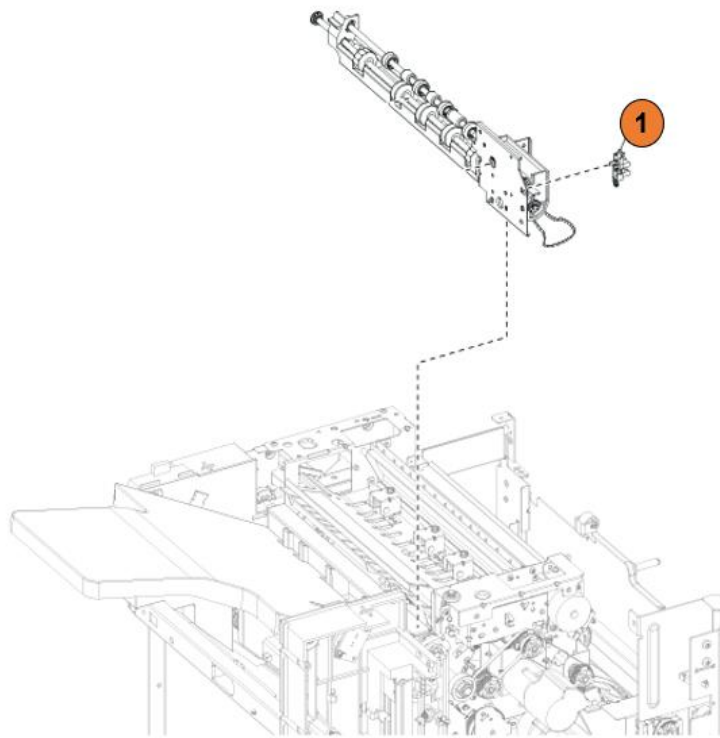

Figure 43.1 MSHPF offset drive

Table 43: MSHPF offset drive - Printed Circuit Boards >10cm² and Plastic with Brominated flame retardants

Item	Description
1	Sensor (offset roller)

Table Component Count (*without options*)

LCD>100cm² = 0
 PCBs>10cm² = 0
 BFR Plastics = 0
 Battery = 0

Section 44: MSHPF standard bin

- LCD > 100 cm²
- PCBs > 10 cm²
- Printer components containing Brominated flame retardants
- Battery

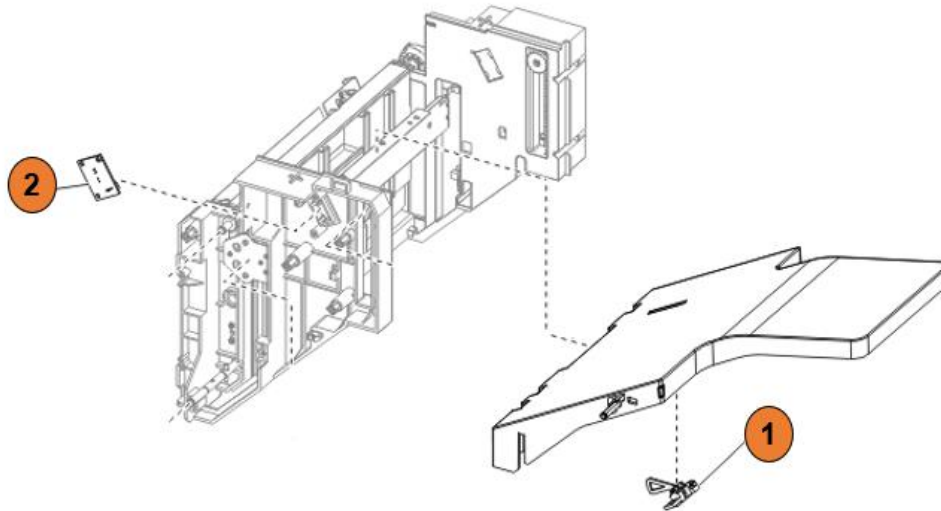

Figure 44.1 MSHPF Standard bin

Table 44: MSHPF standard bin - Printed Circuit Boards >10cm² and Plastic with Brominated flame retardants

Item	Description
1	Sensor (Paper present)
2	Sensor (bin stack upper limit)

Table Component Count (*without options*)

LCD>100cm² = 0
 PCBs>10cm² = 0
 BFR Plastics = 0
 Battery = 0

Section 45: MSHPF standard bin 2

- LCD > 100 cm²
- PCBs > 10 cm²
- Printer components containing Brominated flame retardants
- Battery

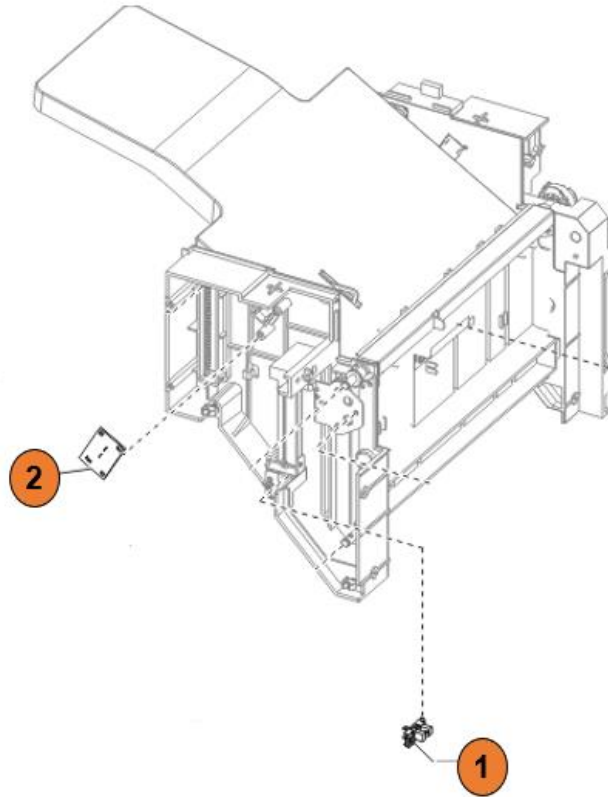

Figure 45.1 MSHPF Standard bin 2

Table 45: MSHPF standard bin 2 - Printed Circuit Boards >10cm² and Plastic with Brominated flame retardants

Item	Description
1	Sensor (lower limit)
2	Sensor (bin stack upper limit receiver)

Table Component Count (*without options*)

LCD>100cm² = 0
 PCBs>10cm² = 0
 BFR Plastics = 0
 Battery = 0

Section 46: MSHPF transport roller and hole punch box

- LCD > 100 cm²
- PCBs > 10 cm²
- Printer components containing Brominated flame retardants
- Battery

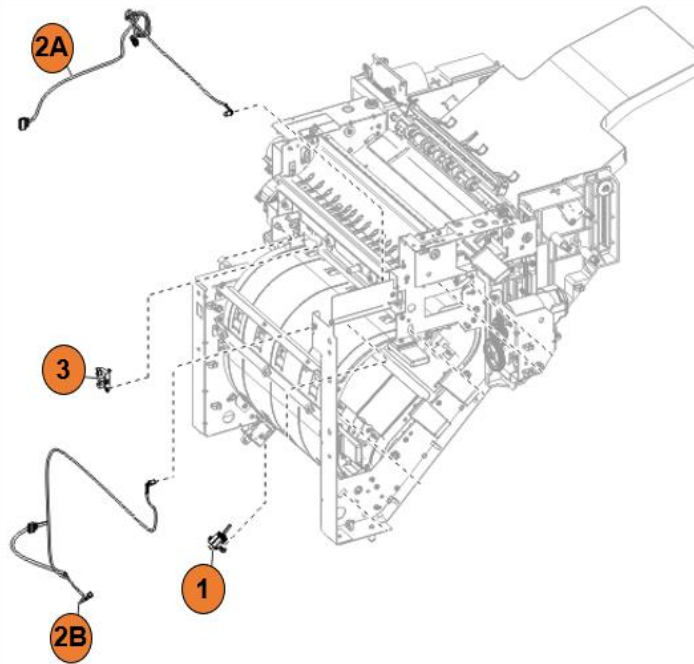

Figure 46.1 MSHPF transport roller and hole punch box

Table 46: MSHPF transport roller and hole punch box - Printed Circuit Boards >10cm² and Plastic with Brominated flame retardants

Item	Description
1	Sensor (Staging outer transport 2)
2A	Sensor (hole punch box full)
2B	Sensor (hole punch box full)
3	Sensor (hole punch box present)

Table Component Count (*without options*)

LCD>100cm² = 0
 PCBs>10cm² = 0
 BFR Plastics = 0
 Battery = 0

Section 47: MSHPF staging drive

- LCD > 100 cm²
- PCBs > 10 cm²
- Printer components containing Brominated flame retardants
- Battery

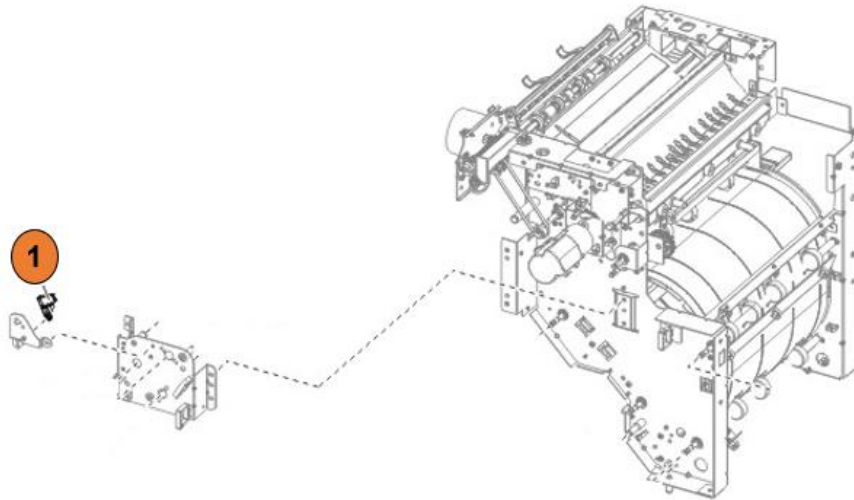

Figure 47.1 MSHPF staging drive

Table 47: MSHPF staging drive - Printed Circuit Boards >10cm² and Plastic with Brominated flame retardants

Item	Description
1	Sensor (diverter)
Table Component Count (without options)	
LCD>100cm ²	= 0
PCBs>10cm ²	= 0
BFR Plastics	= 0
Battery	= 0

Section 48: MSHPF staging paper path

- LCD > 100 cm²
- PCBs > 10 cm²
- Printer components containing Brominated flame retardants
- Battery

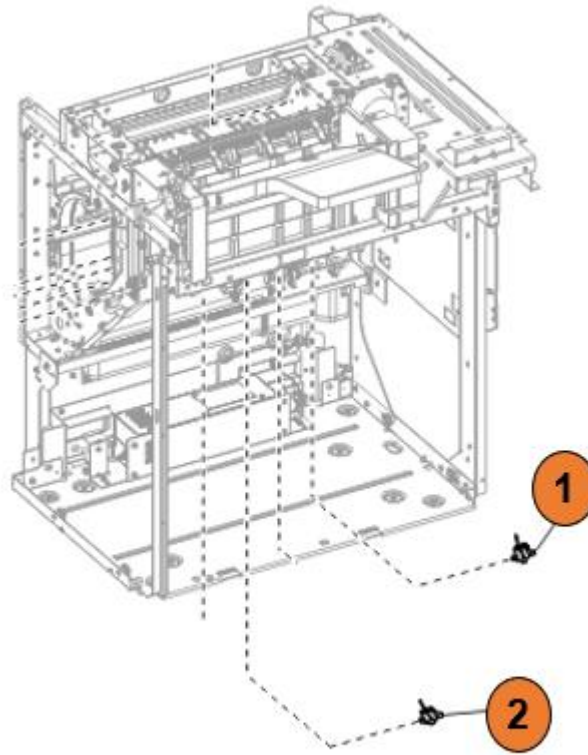

Figure 48.1 MSHPF Staging paper path

Table 48: MSHPF Staging paper path - Printed Circuit Boards >10cm² and Plastic with Brominated flame retardants

Item	Description
1	Sensor (staging inner transport 1)
2	Sensor (staging inner transport 2)

Table Component Count (*without options*)

LCD>100cm² = 0
 PCBs>10cm² = 0
 BFR Plastics = 0
 Battery = 0

Section 49 MSHPF compiler 2

- LCD > 100 cm²
- PCBs > 10 cm²
- Printer components containing Brominated flame retardants
- Battery

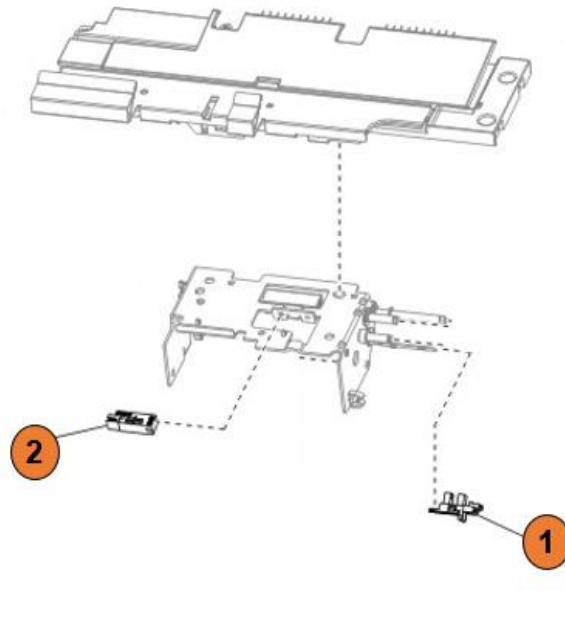

Figure 49.1 MSHPF Compiler 2

Table 49: MSHPF standard bin 2 - Printed Circuit Boards >10cm² and Plastic with Brominated flame retardants

Item	Description
1	Sensor (bin clamp)
2	Sensor (paper present)

Table Component Count (*without options*)

LCD>100cm² = 0
 PCBs>10cm² = 0
 BFR Plastics = 0
 Battery = 0

Section 50: MSHPF Tamper

- LCD > 100 cm²
- PCBs > 10 cm²
- Printer components containing Brominated flame retardants
- Battery

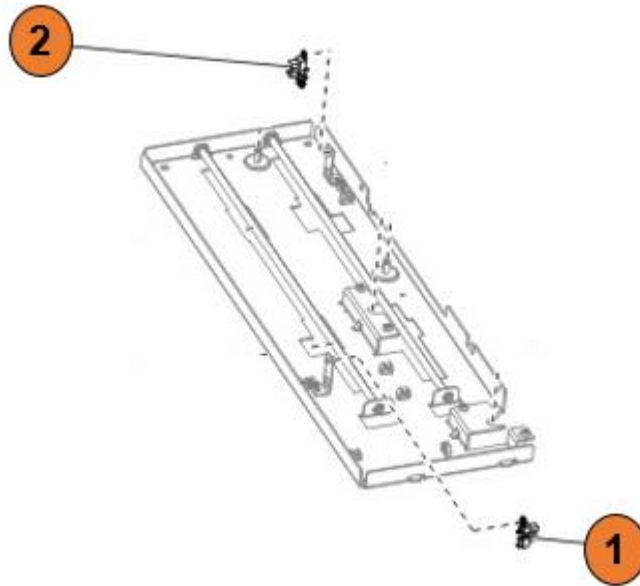

Figure 50.1 MSHPF Tamper

Table 50: MSHPF Tamper - Printed Circuit Boards >10cm² and Plastic with Brominated flame retardants

Item	Description
1	Sensor (Rear tamper)
2	Sensor (Front tamper)

Table Component Count (*without options*)

LCD>100cm² = 0
 PCBs>10cm² = 0
 BFR Plastics = 0
 Battery = 0

Section 51: MSHPF carriage transport

- LCD > 100 cm²
- PCBs > 10 cm²
- Printer components containing Brominated flame retardants
- Battery

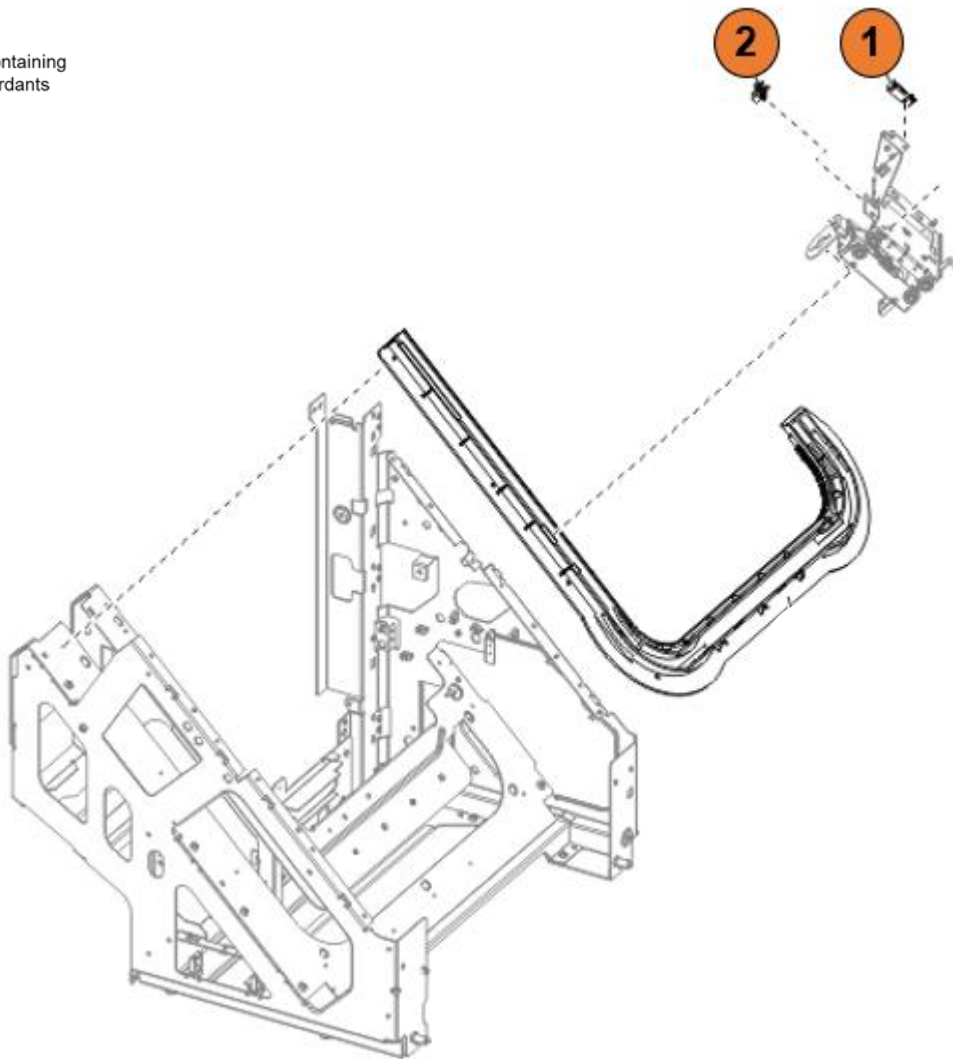

Figure 51.1 MSHPF carriage transport

Table 51: MSHPF carriage transport - Printed Circuit Boards >10cm² and Plastic with Brominated flame retardants

Item	Description
1	Sensor (paper present)
2	Sensor (unit position)

Table Component Count (*without options*)

LCD>100cm² = 0
 PCBs>10cm² = 0
 BFR Plastics = 0
 Battery = 0

Section 52: MSHPF Door interlock

- LCD > 100 cm²
- PCBs > 10 cm²
- Printer components containing Brominated flame retardants
- Battery

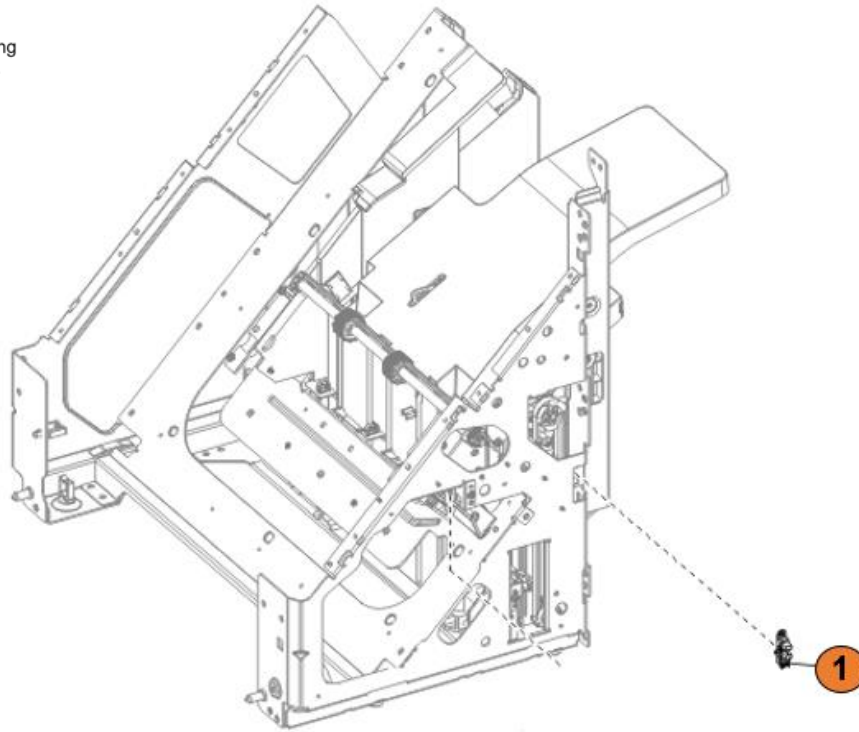

Figure 52.1 Door interlock

Table 52: MSHPF Door interlock - Printed Circuit Boards >10cm² and Plastic with Brominated flame retardants

Item	Description
1	Sensor (door interlock)

Table Component Count (*without options*)

LCD>100cm² = 0
 PCBs>10cm² = 0
 BFR Plastics = 0
 Battery = 0

Section 53: MSHPF stapler bin 1

- LCD > 100 cm²
- PCBs > 10 cm²
- Printer components containing Brominated flame retardants
- Battery

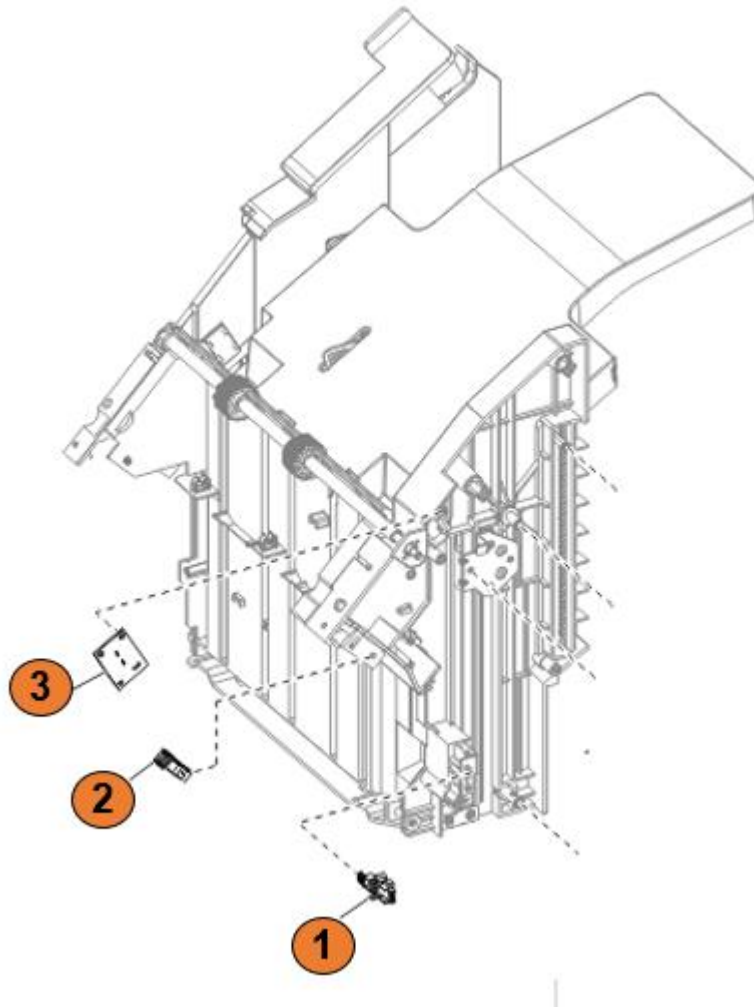

Figure 53.1 MSHPF stapler bin 1

Table 53: MSHPF stapler bin 1 - Printed Circuit Boards >10cm² and Plastic with Brominated flame retardants

Item	Description
1	Sensor (lower limit)
2	Sensor (loading position)
3	Sensor (upper limit)

Table Component Count (*without options*)

LCD>100cm² = 0
 PCBs>10cm² = 0
 BFR Plastics = 0
 Battery = 0

Section 54: MSHPF stapler bin 2

- LCD > 100 cm²
- PCBs > 10 cm²
- Printer components containing Brominated flame retardants
- Battery

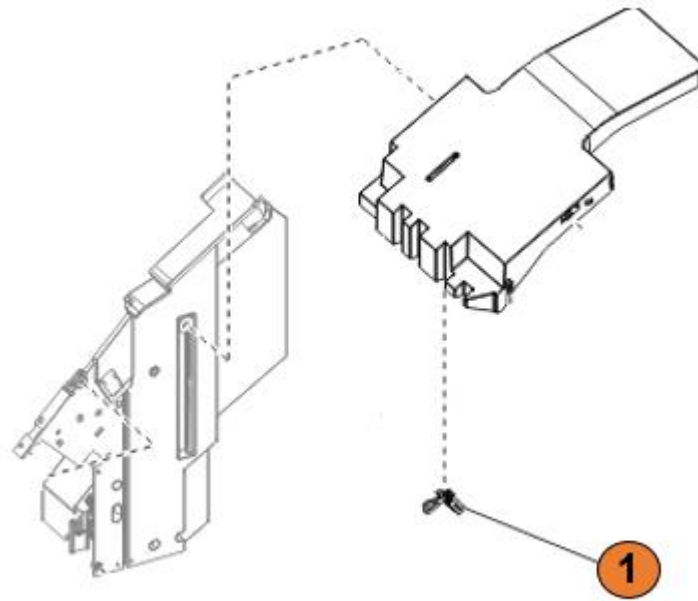
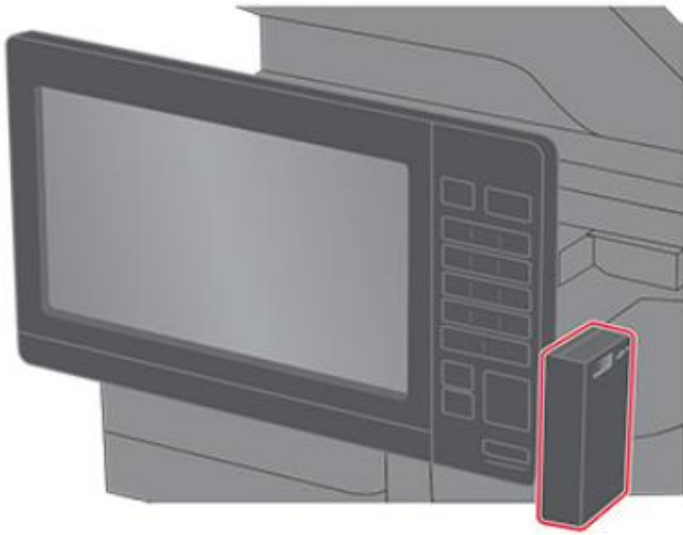

Figure 54.1 MSHPF stapler bin 2

Table 54: MSHPF stapler bin 2 - Printed Circuit Boards >10cm² and Plastic with Brominated flame retardants

Item	Description
1	Sensor (paper present)
Table Component Count (without options)	
LCD>100cm ²	= 0
PCBs>10cm ²	= 0
BFR Plastics	= 0
Battery	= 0

Section 55: For Reference Only (Customer Replaceable External Card Options)



Authentication card readers¹



Keyboard¹

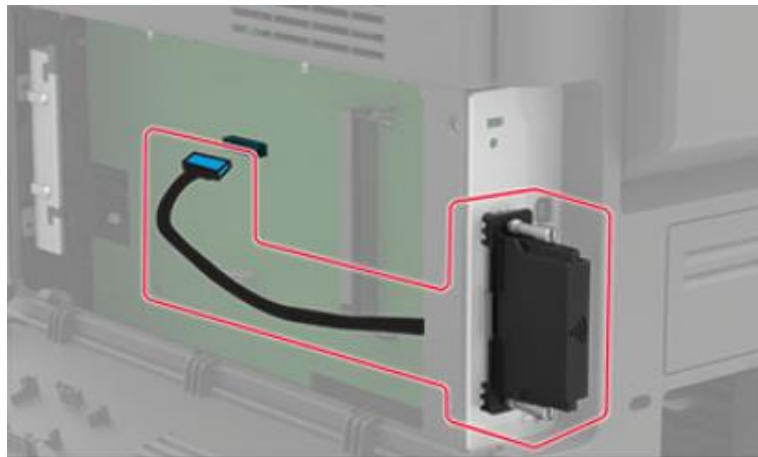

External Print Servers²

Note 1: Illustration shows actual options and their typical locations and mounting at the front side of the printer. However, this does not show the actual printer model.

Note 2: Illustration shows actual options and their typical locations and mounting at the rear side of the printer. However, this does not show the actual printer model.

Annex A – Printer components with Brominated^S Flame Retardants (Page 1 of 6)

Item	Description	Parts Marking	Qty	CS82x	CX82x	CX86x	Location
1	Sensor (ADF multifeed receiver)	N/A	1		X	X	Imaging ADF
2	Sensor (ADF multifeed transmitter)	N/A	1		X	X	ADF 5
3	Sensor (ADF gap detect/ ADF detect)	N/A	2		X	X	ADF 5
4	Sensor (ADF closed)	N/A	1		X	X	ADF 6
5	Sensor (ADF media exit)	N/A	1		X	X	ADF 6
6	Sensor (Exit)	N/A	1		X	X	ADF 6
7	Sensor (ADF pick)	N/A	1		X	X	ADF 6
8	Sensor (ADF 2nd scan)	N/A	1		X	X	ADF 6
9	Sensor (ADF 1st scan)	N/A	1		X	X	ADF 6
10	Sensor (ADF bottom door interlock)	N/A	1		X	X	ADF 6
11	Sensor (ADF top door interlock)	N/A	1		X	X	ADF 6
12	Sensor (Bin full)	N/A	1		X	X	Covers
13	Sensor (Duplex path 1)	N/A	1	X	X	X	Duplex
14	Sensor (Duplex path 2)	N/A	1	X	X	X	Duplex
15	Sensor (pass through)	N/A	1	X	X	X	Left door
16	Sensor (paper present)	N/A	1	X	X	X	Left door
17	Sensor (media out)	N/A	1	X	X	X	Feeder
18	Sensor (index)	N/A	1	X	X	X	Feeder
19	Sensor (media low)	N/A	1	X	X	X	Feeder
20	Sensor (media size)	N/A	1	X	X	X	Feeder
21	21K1216 - Flag	PET-(GF+MD)40 FR(17)	1	X	X	X	Fuser
22	21K1245 - Guide Exit BUR Side	PET-(GF+MD)40 FR(17)	1	X	X	X	Fuser
23	21K1383 - Guide Exit Belt Side	PET-(GF+MD)40 FR(17)	1	X	X	X	Fuser
24	21K1246 - Entry Fuser	PET-(GF+MD)40 FR(17)	1	X	X	X	Fuser
25	Sensor (Photo)	N/A	1	X	X	X	Fuser
26	Sensor (temperature)	N/A	1	X	X	X	Fuser
27	Sensor (fuser temperature)	N/A	1	X	X	X	Fuser
28	HVPS fan	N/A	1	X	X	X	Electronics front
29	Sensor (waste toner bottle present)	N/A	1	X	X	X	Electronics front
30	Sensor (Door interlock)	N/A	1	X	X	X	Electronics front

Annex A – Printer components with Brominated^S Flame Retardants (Page 2 of 6)

Item	Description	Parts Marking	Qty	CS82x	CX82x	CX86x	Location
31	Printhead fan	N/A	1	X	X	X	Electronics front
32	Main fan	N/A	1	X	X	X	Electronics rear
33	Controller board fan	N/A	1	X	X	X	Electronics rear
34	Sensor (weather station)	N/A	1	X	X	X	Electronics rear
35	Sensor (Input)	N/A	1	X	X	X	Registration
36	Sensor (Aperture)	N/A	1	X	X	X	Registration
37	Sensor (Deskew roller exit)	N/A	1	X	X	X	Registration
38	Sensor (Deskew roller entry)	N/A	1	X	X	X	Registration
39	Sensor (Narrow media)	N/A	1	X	X	X	Registration
40	Sensor (Near narrow media)	N/A	1	X	X	X	Registration
41	Sensor (photo)	N/A	1	X	X	X	Registration
42	Sensor (waste toner full)	N/A	1	X	X	X	Motors
43	Printhead tape	N/A	1	X	X	X	Printhead
44	Sensor (Photo)	N/A	1	X	X	X	Redrive
45	Sensor (TPS)	N/A	1	X	X	X	Transfer front
46	Sensor (Auto alignment) 2x	N/A	2	X	X	X	Transfer front
47	Sensor (drive roll)	N/A	1	X	X	X	Transfer front
48	Sensor (media out)	N/A	1	Optional	Optional	Optional	Paper handling
49	Sensor (media size)	N/A	1	Optional	Optional	Optional	Paper handling

Annex A – Printer components with Brominated^S Flame Retardants (Page 3 of 6)

Item	Description	Parts Marking	Qty	CS82x	CX82x	CX86x	Location
50	Sensor (media low)	N/A	1	Optional	Optional	Optional	Paper handling
51	Sensor (index)	N/A	1	Optional	Optional	Optional	Paper handling
52	Sensor (Jam door)	N/A	1	Optional	Optional	Optional	Paper handling
53	Sensor (Passthrough)	N/A	1	Optional	Optional	Optional	Paper handling
54	Sensor (Wake up)	N/A	1	Optional	Optional	Optional	Paper handling
55	Sensor (media low)	N/A	1	Optional	Optional	Optional	2200 Sheet tray
56	Sensor (index)	N/A	1	Optional	Optional	Optional	2200 Sheet tray
57	Sensor (media out)	N/A	1	Optional	Optional	Optional	2200 Sheet tray
58	Sensor (media size)	N/A	1	Optional	Optional	Optional	2200 Sheet tray
59	Sensor (aligner)	N/A	1	Optional	Optional	Optional	Staple finisher front
60	Sensor (exit)	N/A	1	Optional	Optional	Optional	Staple finisher front
61	Sensor (lower bin full)	N/A	1	Optional	Optional	Optional	Staple finisher front
62	Sensor (upper bin full)	N/A	1	Optional	Optional	Optional	Staple finisher front
63	Sensor (Bin full)	N/A	1	Optional	Optional	Optional	Staple finisher Electrical
64	Sensor (slack)	N/A	1	Optional	Optional	Optional	Staple finisher Rear
65	Sensor (bin full)	N/A	1	Optional	Optional	Optional	Staple finisher Rear
66	Sensor (rear)	N/A	1	Optional	Optional	Optional	Staple finisher Tamper
67	Sensor (narrow media)	N/A	1	Optional	Optional	Optional	Staple finisher Tamper
68	Sensor (front)	N/A	1	Optional	Optional	Optional	Staple finisher Tamper

Annex A – Printer components with Brominated^S Flame Retardants (Page 4 of 6)

Item	Description	Parts Marking	Qty	CS82x	CX82x	CX86x	Location
69	Fan	N/A	1		Optional	Optional	HPT Electronics
70	Sensor (Jam cover)	N/A	1		Optional	Optional	HPT Electronics
71	Sensor (stack height)	N/A	1		Optional	Optional	MSHPF Compliler
72	Sensor (exit cam)	N/A	1		Optional	Optional	MSHPF Compliler
73	Sensor (paddle)	N/A	1		Optional	Optional	MSHPF Compliler
74	Sensor (Jam door)	N/A	1		Optional	Optional	Mailbox
75	Sensor (bin 1 full)	N/A	1		Optional	Optional	Mailbox
76	Sensor (Bin 2 full)	N/A	1		Optional	Optional	Mailbox
77	Sensor (Transport)	N/A	1		Optional	Optional	Mailbox
78	Sensor (paper present)	N/A	1		Optional	Optional	Mailbox 4
79	Sensor (paper present)	N/A	1		Optional	Optional	MSHPF Sensors
80	Sensor (Diverter)	N/A	1		Optional	Optional	MSHPF Sensors
81	Sensor (jam cover)	N/A	1		Optional	Optional	HPT Sensors
82	Sensor (transport)	N/A	1		Optional	Optional	HPT Sensors
83	Sensor (entrance)	N/A	1		Optional	Optional	HPT Sensors
84	Sensor (HPT)	N/A	1		Optional	Optional	HPT Sensors
85	Sensor (Diverter)	N/A	1		Optional	Optional	MSHPF mid transport drive
86	Sensor (exit)	N/A	1		Optional	Optional	MSHPF mid-transport paper path
87	Sensor (interlock)	N/A	1		Optional	Optional	MSHPF mid-transport paper path

Annex A – Printer components with Brominated^S Flame Retardants (Page 5 of 6)

Item	Description	Parts Marking	Qty	CS82x	CX82x	CX86x	Location
88	Sensor (staging outer)	N/A	1		Optional	Optional	MSHPF mid-transport paper path
89	Sensor (staging entrance)	N/A	1		Optional	Optional	MSHPF mid-transport paper path
90	Sensor (mid-transport)	N/A	1		Optional	Optional	MSHPF mid-transport paper path
91	Sensor (offset roller)	N/A	1		Optional	Optional	Offset drive
92	Sensor (Paper present)	N/A	1		Optional	Optional	MSHPF Standard bin
93	Sensor (bin stack upper limit)	N/A	1		Optional	Optional	MSHPF Standard bin
94	Sensor (lower limit)	N/A	1		Optional	Optional	MSHPF Standard bin 2
95	Sensor (bin stack upper limit receiver)	N/A	1		Optional	Optional	MSHPF Standard bin 2
96	Sensor (Staging outer transport 2)	N/A	1		Optional	Optional	MSHPF transport roller and hole punch box
97	Sensor (hole punch box full)	N/A	2		Optional	Optional	MSHPF transport roller and hole punch box
98	Sensor (hole punch box present)	N/A	1		Optional	Optional	MSHPF transport roller and hole punch box
99	Sensor (diverter)	N/A	1		Optional	Optional	MSHPF Staging drive
100	Sensor (staging inner transport 1)	N/A	1		Optional	Optional	MSHPF Staging paper path
101	Sensor (staging inner transport 2)	N/A	1		Optional	Optional	MSHPF Staging paper path
102	Sensor (bin clamp)	N/A	1		Optional	Optional	MSHPF Compiler 2
103	Sensor (paper present)	N/A	1		Optional	Optional	MSHPF Compiler 2
104	Sensor (Rear tamper)	N/A	1		Optional	Optional	MSHPF Tamper
105	Sensor (front tamper)	N/A	1		Optional	Optional	MSHPF Tamper
106	Sensor (paper present)	N/A	1		Optional	Optional	MSHPF Carriage transport

Annex A – Printer components with Brominated^S Flame Retardants (Page 6 of 6)

Item	Description	Parts Marking	Qty	CS82x	CX82x	CX86x	Location
107	Sensor (unit position)	N/A	1		Optional	Optional	MSHPF Carriage transport
108	Sensor (door interlock)	N/A	1		Optional	Optional	MSHPF Door interlock
109	Sensor (lower limit)	N/A	1		Optional	Optional	MSHPF Stapler bin 1
110	Sensor (loading position)	N/A	1		Optional	Optional	MSHPF Stapler bin 1
111	Sensor (upper limit)	N/A	1		Optional	Optional	MSHPF Stapler bin 1
112	Sensor (paper present)	N/A	1		Optional	Optional	MSHPF Stapler bin 2
Minimum Count (without options) =			36				

Annex B – Printed Circuit Boards >10cm² (Page 1 of 2)

Item	Description	Qty	CS820	CX82x	CX860	Location
1A	10 in. Button control panel	1			X	Control panel
1B	7 in. Button control panel	1		X		Control panel
1C	4.3 in Button Control panel	1	X			Control panel
2	CCDM, ADF	1		X	X	Imaging ADF
3	ADF Controller board	1		X	X	Imaging ADF
4	Flatbed scanner board	1		X	X	Flatbed scanner 2
5	CCDM, flatbed board	1		X	X	Flatbed scanner 3
6	Fuser PCBA	1		X	X	Fuser
7	Main HVPS	1	X	X	X	Electronics front
8	LVPS	1	X	X	X	Electronics rear
9	Controller board	1	X	X	X	Electronics rear
10	Charge roller HVPS	1	X	X	X	Electronics rear
11	Hard drive	1	Optional	X	X	Electronics rear
12	Fax card	1		X	X	Electronics rear
13	EP developer toner gearbox 1	1	X	X	X	Motors
14	EP developer toner gearbox 2	1	X	X	X	Motors
15	EP developer toner gearbox 3	1	X	X	X	Motors
16	EP developer toner gearbox 4	1	X	X	X	Motors
17	Fuser/ transferbelt gearbox 1	1	X	X	X	Motors
18	Fuser/ transferbelt gearbox 2	1	X	X	X	Motors
19	Hsync card	1	X	X	X	Printhead
20	LD card	1	X	X	X	Printhead
21	Smart chip interface board	1	X	X	X	Toner Supply
22	550-sheet tray controller board	1	Optional	Optional	Optional	Paper handling
23	550-sheet tray controller board	1	Optional	Optional	Optional	2000 Sheet
24	Finisher controller board	1		Optional	Optional	MSHPPF electronics
25	Mid-transport interface board	1		Optional	Optional	MSHPPF electronics
26	MSHPPF power supply	1		Optional	Optional	MSHPPF electronics
27	MSHPPF controller board	1		Optional	Optional	MSHPPF electronics

Annex B – Printed Circuit Boards >10cm² (Page 2 of 2)

Item	Description	Qty	CS820	CX82x	CX860	Location
28	Compiler interface board	1		Optional	Optional	MSHPPF compiler
29	HPT controller board	1		Optional	Optional	HPT electronics
30	Mailbox controller board	1		Optional	Optional	Mailbox
Minimum Count (without Options)		14	14	21	21	

Annex C – Electrical and Electronic (EE) Customer Replaceable Paper handling devices

Item	PN	Description	CS82x	CX82x	CX86x	Locations
1	21K0567	550-Sheet Tray	X	X	X	Paper handling devices
2	21K0787	Envelope Tray	X	X	X	Stapler option
3	21K0237	2200-Sheet Tray	X	X	X	2200 Sheet
4	42K2000	CS/CX820 Staple Finisher	X	X	X	Staple finisher
5	42K2300	CX825/CX860 Staple Finisher		X	X	Staple finisher

Annex D – Electrical and Electronic (EE) Customer Replaceable Internal/ External Card Option

Item	PN	Description	CS82x	CX82x	CX86x	Locations
1	27X0400	320+GB Hard Disk Drive	X	X	X	Attached to Controller board
2	57X9022	2GB DDR3 SO-DIMM (x64)	X	X	X	
3	57X9801	256MB User Flash	X	X	X	
4	21K0127	Forms and Bar Code (FMBC) eMMC Card	X	X	X	
5	21K0128	IPDS eMMC Card	X	X	X	
6	21K0129	PRESCRIBE eMMC Card	X	X	X	
7	57X9810	Font cards	X	X	X	
8	27X6510	MarkNet N8370 802.11 a/b/g/n/ac	X	X	X	External option