

# Lexmark X792 Family colour laser MFPs



## Business productivity with robust colour performance

### Models



#### Lexmark X792 Family

The Lexmark X792 Family colour MFPs elevate your workgroup productivity through brilliant colour printing, productivity solutions, flexible features and an intuitive colour touch screen.

#### Other available models:

**Lexmark X792de:** Includes duplex and hard disk

**Lexmark X792dte:** Includes duplex, hard disk, three 550-sheet trays and caster base

**Lexmark X792dtfe:** Includes duplex, hard disk, two 550-sheet trays, stapling and caster base

**Lexmark X792dtpe:** Includes duplex, hard disk, two 550-sheet trays, stapling with hole punch and caster base

**Lexmark X792dtme:** Includes duplex, hard disk, two 550-sheet trays, a five-bin mailbox and caster base

**Lexmark X792dtse:** Includes duplex, hard disk, two 550-sheet trays, an offset stacker and caster base



Colour



Touch screen



Copy



Scan



Fax



Solutions



Up to 50 ppm



Duplex



Network

**LEXMARK**  
TM

# Lexmark X792 Family: key features



Lexmark X792de colour laser MFP shown with optional input drawers, hard disk, stapler with hole punch finisher and caster base.

## Features that help you optimize your work



### 1) Intuitive colour touch screen

The extra large 10.2-inch colour touch screen allows you to operate your printer with ease and confidence through smart and intuitive navigation, easy access to workflow solutions and shortcuts, and the ability to preview your documents and print jobs at the device.



### 2) Flexible output options

Choose from four output options, including a five-bin mailbox, an offset stacker, a staple finisher, and a staple with hole punch finisher.



### 3) Duplex automatic document feeder (DADF)

Save time by scanning both sides of your document in one pass with robust colour-scanning capabilities and an input capacity of up to 75 pages.



### 4) Direct USB

The front USB port allows for convenient walk-up preview, printing and scanning, and is compatible with most printable image file formats.



### 5) Lexmark solutions

Reduce unnecessary printing and simplify work processes through solutions applications preloaded on your device. Choose additional Lexmark solutions to fit your unique workflow needs.



### 6) Long-lasting toner

The Lexmark Extra High Yield Print Cartridge delivers up to 20,000\* pages, reducing interventions, cartridge waste and cost.



### 7) Eco-friendly features

Easy-to-access features make it easy to print responsibly, including Eco-Mode to reduce paper and toner consumption, and the Sleep button and Hibernate Mode to help you save energy.

\* Average continuous black or composite CMY declared cartridge yield in accordance with ISO/IEC 19798

# Lexmark X792 Family: overview



## Robust Colour Printing

Designed for busy colour printing environments, the Lexmark X792 Family delivers vibrant, professional quality output that is consistent from the first page to the last.

- Lexmark Extra High Yield Print Cartridge available, offering yields of up to 20,000\* pages
- Print and copy in duplex at speeds as fast as 50 ppm in both black and colour
- PANTONE® calibration for consistent colour tones
- Named Colour Replacement for easy colour matching
- Lexmark Colour Care Technology to manage colour usage and control costs
- Instant warm-up fuser to help reduce energy consumption and improve time to first page



## Business Productivity

The Lexmark X792 Family combines exceptional multifunction performance with time-saving applications designed to make you more productive. These MFPs can deliver the performance of much larger copiers, but with a smaller footprint and a more affordable price.

- Duplex scanning to scan both sides of your documents in one pass
- Advanced copy functions let you interrupt long print runs to make a quick copy, and proof the first copy set before completing your copy job
- Scan to multiple destinations, including scan to email, scan to FTP, scan to fax, scan to network, and more
- Preloaded applications to drive greater efficiency, and Lexmark Embedded Solutions Framework to further extend the capabilities of the device



## Flexibility

Select from a number of expandability options and finishing features you would expect from more expensive products.

- Ultra-reliable paper feeding to support diverse media, including card stock, labels, UV-resistant outdoor media, banner media and more
- Robust output options, including a five-bin user-assignable mailbox, an offset stacker, a staple finisher, and a staple with hole punch finisher
- Input capacity expandable up to 2,650 sheets with a high-capacity feeder or extra drawers
- Connectivity and application solution cards allow integration into most IT environments



## Easy and Intuitive

The Lexmark X792 Family is designed for easy operation and maintenance.

- Extra large, easy to navigate 10.2-inch colour touch screen provides audible and tactile feedback to make completing tasks intuitive
- Print and scan preview features help you select documents or specific pages within a document
- Directional lights on the device provide visual cues to guide you through tasks and maintenance operations
- Eco-friendly settings such as the Sleep button and Hibernate Mode
- Available device fleet management software

## Print Less. Save More.

Print less? This may seem like a surprising message for a company dedicated solely to printing. But when you consider that businesses spend, on average, up to 6% of their turnover on printing, and that active print management can cut office print costs by up to 30%\*, it makes a lot of sense. Lexmark products, solutions and services provide innovative ways to save you time, drive down costs and reduce your impact on the environment. We are committed to helping you print less and save more.



### Solutions

## Save time and money through solutions

Reduce unnecessary printing and simplify work processes through Lexmark solutions. The X792 Family features the Lexmark Embedded Solutions Framework (eSF), our platform that enables you to add a wide range of software applications directly onto the device. Solutions are designed with your productivity in mind, helping you streamline—or even eliminate—paper intensive business processes.

### The following are solutions that come preloaded on the X792 Family:



#### Forms and Favourites

Eliminate waste and inefficiencies associated with preprinted forms. Store frequently printed forms, marketing materials or other documents online, then print them on demand.



#### Scan to Network

Scan a hardcopy document and route the image to one of 30 predefined personal or public shared network folders.



#### Change Language\*\*

Easily switch the language displayed on the touch screen – 18 languages supported.

### The following are a few of the Lexmark solutions available through authorized partners or Lexmark Professional Services:



#### Showroom

Display a customizable, scrolling slideshow on the colour touch screen to promote your business or products, or to communicate important messages to your customers or employees.



#### Card Copy

Save time and effort in copying identification cards, licenses and insurance cards by automatically scanning, enlarging and printing both sides of a two-sided card onto one side of a sheet of paper.

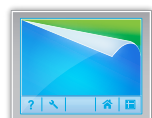

#### Background and Idle Screen

Change the touch screen background to your corporate logo, a unique message or select one of four available screens.

\* Source: InfoTrends/CapVentures., «Network Document Solutions Forecast 2007-2012, Network Document Solutions Consulting Service», August, 2008

\*\* Option to Change Language during installation

## Lexmark X792 Family: highlights

### Make a lasting impression with award-winning colour

The documents you print define an important image – yours. That's why Lexmark's colour MFPs help businesses be more productive and stand out with vibrant colour. With the ability to print professional quality colour in-house, you can add instant impact and save costs by virtually eliminating the need to outsource print jobs. Lexmark also offers a host of colour-access and control tools to manage costs.



#### Functions



### The right touch

The Lexmark e-Task colour touch screen is a key access point to your printer. The extra large customizable 10.2-inch interface gives you the ability to preview thumbnails of documents prior to printing, as well as change print jobs at the device. You can even view, select and print specific pages within a document directly from the touch screen. Its easy-to-use, intuitive navigation provides fast access to the functions, shortcuts and workflows you use most, and through the MyMFP feature, you can tailor your device with personal settings. New interactive sensory features provide both tactile and audible feedback, helping to guide you through each operation, confirming a touch has registered and indicating an action is transpiring.



### Protecting your information

From the data traveling through your network to the pages being printed, Lexmark's innovative security controls give you peace of mind that your valuable corporate data is protected at every stage.

- Cutting-edge user authentication and authorization controls, including LDAP, help protect your device and data
- Card reader option to add an extra layer of security
- Hard disk encryption protects sensitive data on the disk drive
- Automatic, scheduled or manual disk wiping
- IPSec, SNMPv3 and 802.1x network security supported
- Security-audit logging to help track and identify security risks



### True Image Always

Lexmark is dedicated to designing and manufacturing products that deliver exceptional quality and reliable performance. Maximize the return on your investment, extend the service life of your Lexmark printing equipment, and make a lasting impression by always insisting on Lexmark Genuine Supplies, Service and Parts. Lexmark X792 Family colour laser printers are backed by a one-year base warranty. For further protection against unexpected expenses or downtime, extended warranty offerings are available.

# Lexmark X792 Family: ordering information

## Lexmark X792dtfe

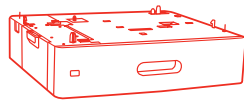
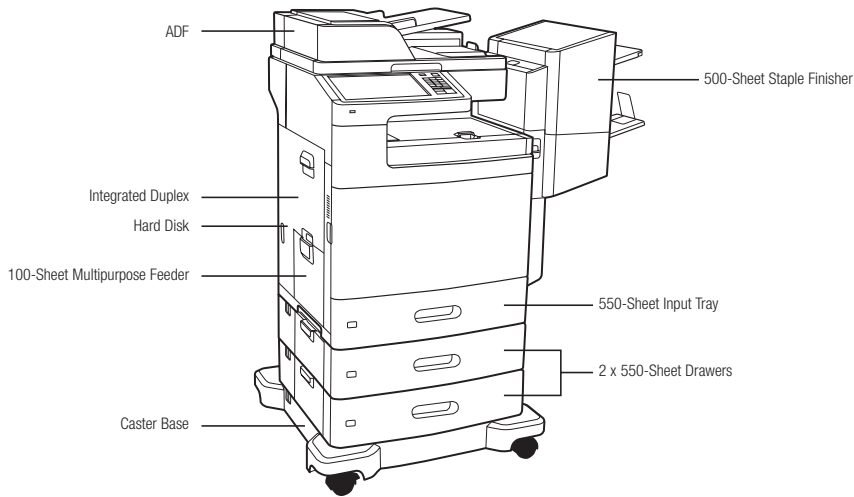

550-Sheet Drawer

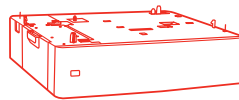

Spacer



## Compatible on the complete X792 Family

### Part # Laser Toner/Print Cartridge

X792X1KG	X792 Black Extra High Yield Return Program Print Cartridge
X792X1CG	X792 Cyan Extra High Yield Return Program Print Cartridge
X792X1MG	X792 Magenta Extra High Yield Return Program Print Cartridge
X792X1YG	X792 Yellow Extra High Yield Return Program Print Cartridge
C792A1KG	C792, X792 Black Return Program Print Cartridge
C792A1CG	C792, X792 Cyan Return Program Print Cartridge
C792A1MG	C792, X792 Magenta Return Program Print Cartridge
C792A1YG	C792, X792 Yellow Return Program Print Cartridge
X792X2KG	X792 Black Extra High Yield Print Cartridge
X792X2CG	X792 Cyan Extra High Yield Print Cartridge
X792X2MG	X792 Magenta Extra High Yield Print Cartridge
X792X2YG	X792 Yellow Extra High Yield Print Cartridge
C792X77G	C792, X792 Waste Toner Bottle
25A0013	Staple Cartridges (3 pack)

### Part # Memory Options

1025041	256MB DDR2-DRAM
1025042	512MB DDR2-DRAM
1025043	1024MB DDR2-DRAM
14F0245	256MB Flash Card
30G0287	Arabic Font Card
30G0828	Japanese Font Card
30G0825	Korean Font Card

### Part # Application Solutions

47B1111	X792 Card for IPDS
---------	--------------------

47B1110	X792 Forms and Bar Code Card
47B1112	X792 Card for PRESCRIBE Emulation
57X9000	Lexmark PrintCryption Card

### Part # Connectivity

27X0025	MarkNet N8250 802.11b/g/n Wireless Print Server
14F0037	MarkNet™ N8020 Gigabit Ethernet Print Server
14F0042	MarkNet N8130 Fiber Ethernet 100BaseFX, 10BaseFL Print Server
14T0220	MarkNet™ N7020e Gigabit Ethernet Print Server
1021294	USB (2 Meter) Cable
14F0000	Parallel 1284-B Interface Card
14F0100	RS-232C Serial Interface Card

### Part # User Replaceable Parts

40X7100	C792, X792 Fuser Maintenance Kit 110-120V
40X7101	C792, X792 Fuser Maintenance Kit 220-240V
40X7103	C792, X792 Transfer module Maintenance Kit
40X7220	X792 ADF Maintenance Kit



## Eco-responsible printing

Printing responsibly means everyone wins – your business, your budget and the environment. Lexmark's award-winning products are designed for ease of use, high quality output and reliable performance, with innovative capabilities that help you minimize the number of cartridges you use over the life of the printer and conserve paper and energy. Our goal is to design, package and deliver innovative products and solutions in an environmentally responsible manner.

# Lexmark X792 Family: ordering information

## Lexmark X792de

Part #	Model	2353777	X792 2-Years Onsite Service, Next Business Day
47B1000	Lexmark X792de	2353778	X792 3-Years Onsite Service, Next Business Day
		2353779	X792 4-Years Onsite Service, Next Business Day
		2353780	X792 1-Year Onsite Service Renewal, Next Business Day
Part #	Paper Handling	Part #	Installation Service
47B0110	C792, X792 550-Sheet Drawer	2353783	X792 Install, De-Install Service
47B0111	C792, X792 2000-Sheet High Capacity Feeder		
47B1101	C792, X792 5-Bin Mailbox		
47B1102	C792, X792 500-Sheet Offset Stacker		
47B1100	C792, X792 500-Sheet Staple Finisher		
47B1103	C792, X792 500-Sheet Staple, Hole Punch Finisher		
47B0112	C792, X792 Spacer		
Part #	Extended Warranties		
2353776	X792 1-Year Onsite Service, Next Business Day		

### In the box

Lexmark X792de colour laser multifunction printer, Up to 12,000\*-page Black, Cyan, Magenta, Yellow Starter Print Cartridges, Software and Documentation CD, Power Cord(s), RJ-11 Phone cable or adapter (country dependent), Setup Guides (network and local attachment), Statement of limited warranty / guarantee, Lexmark Cartridge Collection Program information

## Lexmark X792dtfe

Part #	Model	Part #	Installation Service
47B1002	Lexmark X792dtfe	2353783	X792 Install, De-Install Service
Part #	Paper Handling		
47B0110	C792, X792 550-Sheet Drawer		
47B0112	C792, X792 Spacer		
Part #	Extended Warranties		
2353776	X792 1-Year Onsite Service, Next Business Day		
2353777	X792 2-Years Onsite Service, Next Business Day		
2353778	X792 3-Years Onsite Service, Next Business Day		
2353779	X792 4-Years Onsite Service, Next Business Day		
2353780	X792 1-Year Onsite Service Renewal, Next Business Day		

### In the box

Lexmark X792de colour laser Multifunction printer, Up to 12,000\*-page Black, Cyan, Magenta, Yellow Starter Print Cartridges, 2 x 550-Sheet drawers, Staple finisher, Caster base, Software and Documentation CD, Power Cord(s), RJ-11 Phone cable or adapter (country dependent), Setup Guides (network and local attachment), Statement of limited warranty / guarantee, Lexmark Cartridge Collection Program information

## Lexmark X792dtme

Part #	Model	Part #	Installation Service
47B1121	Lexmark X792dtme	2353783	X792 Install, De-Install Service
Part #	Paper Handling		
47B0110	C792, X792 550-Sheet Drawer		
47B0112	C792, X792 Spacer		
Part #	Extended Warranties		
2353776	X792 1-Year Onsite Service, Next Business Day		
2353777	X792 2-Years Onsite Service, Next Business Day		
2353778	X792 3-Years Onsite Service, Next Business Day		
2353779	X792 4-Years Onsite Service, Next Business Day		
2353780	X792 1-Year Onsite Service Renewal, Next Business Day		

### In the box

Lexmark X792de colour laser multifunction printer, Up to 12,000\*-page Black, Cyan, Magenta, Yellow Starter Print Cartridges, 2 x 550-Sheet drawers, 5-Bin Mailbox, Caster base, Software and Documentation CD, Power Cord(s), RJ-11 Phone cable or adapter (country dependent), Setup Guides (network and local attachment), Statement of limited warranty / guarantee, Lexmark Cartridge Collection Program information

## Lexmark X792dtpe

Part #	Model	Part #	Installation Service
47B1120	Lexmark X792dtpe	2353783	X792 Install, De-Install Service
Part #	Paper Handling		
47B0110	C792, X792 550-Sheet Drawer		
47B0112	C792, X792 Spacer		
Part #	Extended Warranties		
2353776	X792 1-Year Onsite Service, Next Business Day		
2353777	X792 2-Years Onsite Service, Next Business Day		
2353778	X792 3-Years Onsite Service, Next Business Day		
2353779	X792 4-Years Onsite Service, Next Business Day		
2353780	X792 1-Year Onsite Service Renewal, Next Business Day		

### In the box

Lexmark X792de colour laser multifunction printer, Up to 12,000\*-page Black, Cyan, Magenta, Yellow Starter Print Cartridges, 2 x 550-Sheet drawers, Staple, punch finisher, Caster base, Software and Documentation CD, Power Cord(s), RJ-11 Phone cable or adapter (country dependent), Setup Guides (network and local attachment), Statement of limited warranty / guarantee, Lexmark Cartridge Collection Program information

## Lexmark X792dtse

Part #	Model	Part #	Installation Service
47B1122	Lexmark X792dtse	2353783	X792 Install, De-Install Service
Part #	Paper Handling		
47B0110	C792, X792 550-Sheet Drawer		
47B0112	C792, X792 Spacer		
Part #	Extended Warranties		
2353776	X792 1-Year Onsite Service, Next Business Day		
2353777	X792 2-Years Onsite Service, Next Business Day		
2353778	X792 3-Years Onsite Service, Next Business Day		
2353779	X792 4-Years Onsite Service, Next Business Day		
2353780	X792 1-Year Onsite Service Renewal, Next Business Day		

### In the box

Lexmark X792de colour laser multifunction printer, Up to 12,000\*-page Black, Cyan, Magenta, Yellow Starter Print Cartridges, 2 x 550-Sheet drawers, Offset Stacker, Caster base, Software and Documentation CD, Power Cord(s), RJ-11 Phone cable or adapter (country dependent), Setup Guides (network and local attachment), Statement of limited warranty / guarantee, Lexmark Cartridge Collection Program information

# Lexmark X792 Family: product specifications

	Lexmark X792de	Lexmark X792dte	Lexmark X792dtme	Lexmark X792dtpc
<b>Printing</b>				
<b>Print Technology</b>	Colour Laser			
<b>Print Speed (Letter, Black): Up to</b>	50 ppm			
<b>Print Speed (Letter, Colour): Up to</b>	50 ppm			
<b>Time to First Page (Black)</b>	As fast as 8 seconds			
<b>Time to First Page (Colour)</b>	as fast as 8.5 seconds			
<b>Print Resolution, Black</b>	1200 x 1200 dpi, 4800 Colour Quality (2400 x 600 dpi)			
<b>Print Resolution, Colour</b>	1200 x 1200 dpi, 4800 Colour Quality (2400 x 600 dpi)			
<b>Memory, Standard</b>	1024 MB			
<b>Memory, Maximum</b>	2048 MB			
<b>Hard Disk</b>	Included in configuration			
<b>Print Noise Level, Operating</b>	52 dBA			
<b>Noise Level, Idle</b>	27 dBA			
<b>Maximum Monthly Duty Cycle: Up to</b>	150000 pages per month			
<b>Recommended Monthly Page Volume</b>	2500 - 17000 pages			
<b>Supplies</b>				
<b>Supplies Yield</b>	6,000*-page (CMYK) Print Cartridges, 20,000*-page (CMYK) Extra High Yield Print Cartridges			
(*Average continuous black or continuous composite CMY declared cartridge yield up to this number of standard pages in accordance with ISO/IEC 19798.)				
<b>Copying</b>				
<b>Copy Speed (Letter, Black): Up to</b>	50 cpm			
<b>Copy Speed (Letter, Colour): Up to</b>	50 cpm			
<b>Scanning</b>				
<b>ADF Scan</b>	DADF (single pass Duplex)			
<b>Scanning Resolution</b>	600 X 600 dpi			
<b>Reduce / Enlarge Range</b>	25 - 400 %			
<b>Faxing</b>				
<b>Modem Speed</b>	33.6 Kbps			
<b>Paper Handling</b>				
<b>Paper Handling Standard</b>	500-Sheet Output Bin, Integrated Duplex, 100-Sheet Multipurpose Feeder, 550-Sheet Input Tray	500-Sheet Output Bin, Integrated Duplex, 100-Sheet Multipurpose Feeder, 550-Sheet Input Tray, 2 x 550-Sheet Drawers	500-Sheet Output Bin, Integrated Duplex, 100-Sheet Multipurpose Feeder, 550-Sheet Input Tray, 2 x 550-Sheet Drawers, 5-Bin Mailbox	500-Sheet Output Bin, Integrated Duplex, 100-Sheet Multipurpose Feeder, 550-Sheet Input Tray, 2 x 550-Sheet Drawers, 500-Sheet Staple Punch
<b>Paper Handling Optional</b>	5-Bin Mailbox, 550-Sheet Drawer, 2,000-Sheet High Capacity Feeder, 500-Sheet Offset Stacker, 500-Sheet Staple Finisher, 500-Sheet Staple Punch Finisher	5-Bin Mailbox, 550-Sheet Drawer, Banner Media Tray, 500-Sheet Offset Stacker, 500-Sheet Staple Finisher, 500-Sheet Staple Punch Finisher	550-Sheet Drawer	550-Sheet Drawer
<b>Paper Input Capacity, Standard: Up to</b>	650 pages 20 lb or 75 gsm bond	1750 pages 20 lb or 75 gsm bond	1750 pages 20 lb or 75 gsm bond	1750 pages 20 lb or 75 gsm bond
<b>Paper Input Capacity, Maximum: Up to</b>	2650 pages 20 lb or 75 gsm bond	2300 pages 20 lb or 75 gsm bond	2300 pages 20 lb or 75 gsm bond	2300 pages 20 lb or 75 gsm bond
<b>ADF Paper Input Capacity : Up to</b>	75 pages 20 lb or 75 gsm bond			
<b>Media Types Supported</b>	Card Stock, Dual Web Labels, Envelopes, Glossy paper, Integrated Labels, Paper Labels, Plain Paper, Polyester Labels, Transparencies, Vinyl Labels, Refer to the Card Stock & Label Guide, Outdoor Media, Banner Paper	Card Stock, Dual Web Labels, Envelopes, Glossy paper, Integrated Labels, Paper Labels, Plain Paper, Polyester Labels, Transparencies, Vinyl Labels, Refer to the Card Stock & Label Guide, Outdoor Media, Banner Paper	Card Stock, Dual Web Labels, Envelopes, Glossy paper, Integrated Labels, Paper Labels, Plain Paper, Polyester Labels, Transparencies, Vinyl Labels, Refer to the Card Stock & Label Guide, Outdoor Media	Card Stock, Dual Web Labels, Envelopes, Glossy paper, Integrated Labels, Paper Labels, Plain Paper, Polyester Labels, Transparencies, Vinyl Labels, Refer to the Card Stock & Label Guide, Outdoor Media
<b>General</b>				
<b>Function</b>	Colour Copying, Colour Faxing, Colour Printing, Colour Scanning, Colour Network Scanning			
<b>Product Warranty</b>	1-Year Onsite Service, Next Business Day			
<b>Product Certifications</b>	www.lexmark.ca			
<b>Size (in. - H x W x D)</b>	32.5 x 22.0 x 20.0 in.	47.4 x 24.05 x 25.9 in.	47.4 x 41.55 x 25.9 in.	47.4 x 41.55 x 25.9 in.
<b>Weight (lb.)</b>	161 lb.	247 lb.	279 lb.	285 lb.
<b>Specified Operating Environment</b>	Temperature: 16 to 32°C (60 to 90°F), Humidity: 8 to 80% Relative Humidity, Altitude: 0 - 3048 Meters (10,000 Feet)			
<b>Furniture</b>				
<b>Caster Base</b>	Optional, (Required for floor standing configuration)	(Included)	(Included)	(Included)
<b>Spacer</b>	Available			

#### Recommended Monthly Page Volume

«Recommended Monthly Page Volume» is a range of pages that helps customers evaluate Lexmark's product offerings based on the average number of pages customers plan to print on the device each month. Lexmark recommends that the number of pages per month be within the stated range for optimum device performance, based on factors including: supplies replacement intervals, paper loading intervals, speed, and typical customer usage.

#### Maximum Monthly Duty Cycle

«Maximum Monthly Duty Cycle» is defined as the maximum number of pages a device could deliver in a month using a multishift operation. This metric provides a comparison of robustness in relation to other Lexmark printers and MFPs.

#### Trademarks

Lexmark and Lexmark with the diamond design are trademarks of Lexmark International, Inc., registered in the United States and/or other countries. All other trademarks are the property of their respective owners. ENERGY STAR® is a U.S. registered mark. Information in this document is subject to change without notice. PANTONE® is a registered trademark of Pantone, Inc. This product features Adobe® Flash® technology. For further information, visit <http://www.adobe.com/software/flash/about/>

Print Less. Save More.

[www.lexmark.ca](http://www.lexmark.ca)



**LEXMARK**  
TM